



# SUZUKI

## MARINE

### Parts Book

DT 20 (77-79)

DT 25 (77-79)

DT 28 (77-79)

PREFACE

This parts catalogue has been arranged to include all prior modification as the final edition.  
 No revised edition will be issued any more and be sure to make use of this in good keeping.  
 Upon receipt of this final edition, the old catalogue should be thrown away.  
 This parts catalogue covers the list of all service parts for SUZUKI DT9.9~DT28 (C, D, F).

A. INSTRUCTIONS FOR QUOTING THE CATALOGUE

1. DIMENSIONS

Dimensions of the parts in this catalogue are indicated in unit millimeters.

2. ABBREVIATIONS

Abbreviations used in this catalogue are as follows:

AR	: As required	NT	: Number of teeth
ASSY	: Assembly	OPT	: Optional
E.No.	: Engine Number	OS	: Over Size
F.No.	: Frame Number	STD	: Standard
d	: Diameter of material	T	: Thickness
ID	: Inside diameter	US	: Under size
OD	: Outside diameter	W	: Width
L	: Length	S,L,UL,LL	: Transom type
LH	: Left hand side		
RH	: Right hand side		
~100045	: Up to E.No.-100045		
100046~	: From E.No.-100046		

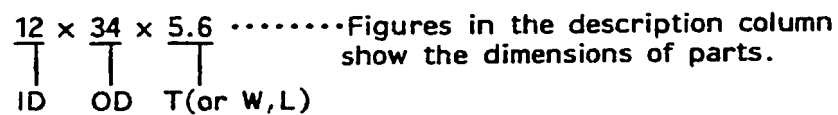

To 12340-56781 (Parts No.) : indicates that the parts number was changed to 12345-56781 and the new parts are interchangeable with the former ones but the former ones are not interchangeable with new ones.

From 12345-56781 (Parts No.) : indicates that the former and new parts are interchangeable with each other and both are usable.

The number of letter shown below Q'ty indicate the MODEL NAME as shown right side.

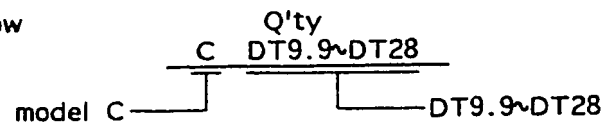

3. INNER PARTS OF ASSEMBLY

Parts number that have a period (.) mark in front of the part description on a text page are separately serviced parts of the assembly.

4. MODIFICATION NOTICE

A parts bulletin will be sent to you on all occasions when changes in parts occur, including interchangeable modifications between new parts and old ones.

5. NOTE

- 5-1. There are some different parts from those of production models among spare parts for the administrative reasons and common use of them with other models.
- 5-2. In respect of rubber hoses and vinyl tubes, please be sure to use them by cutting off according to the length mentioned on parts catalogue or what is actually required on the vehicle.
- 5-3. Note that the drawings on the illustration page are for ready reference of spare parts number, not to be used as an assembly manual.  
When assembling, use "SUZUKI SERVICE MANUAL".

6. SPECIFICATION CODE

This catalogue contains the parts for the model designed for the following spec. ;  
 spec. code: DT9.9C (E1, E13, E28), DT9.9D (E1, E3, E13), DT9.9F (E1, E3, E9, E13, E38), DT9.9YD (E1), DT9.9YF (E1, E3), DT14C (E1, E13, E28), DT14D (E1, E13), DT14F (E1, E13, E38), DT16C (E1, E13, E28, E37), DT16D (E1, E3, E13), DT16F (E1, E3, E9, E13, E38), DT20C (E1, E13, E28), DT20D (E1, E3, E13), DT20F (E1, E3, E9, E13), DT25C (E1, E13, E28, E37), DT25D (E1, E3, E13), DT25F (E1, E3, E9, E13), DT28F (E1, E9)

7. SERIAL FRAME NUMBER

C-10001~, D-10001~, F-10001~

FIG. 27

G - 2

FIG. 27 CYLINDER

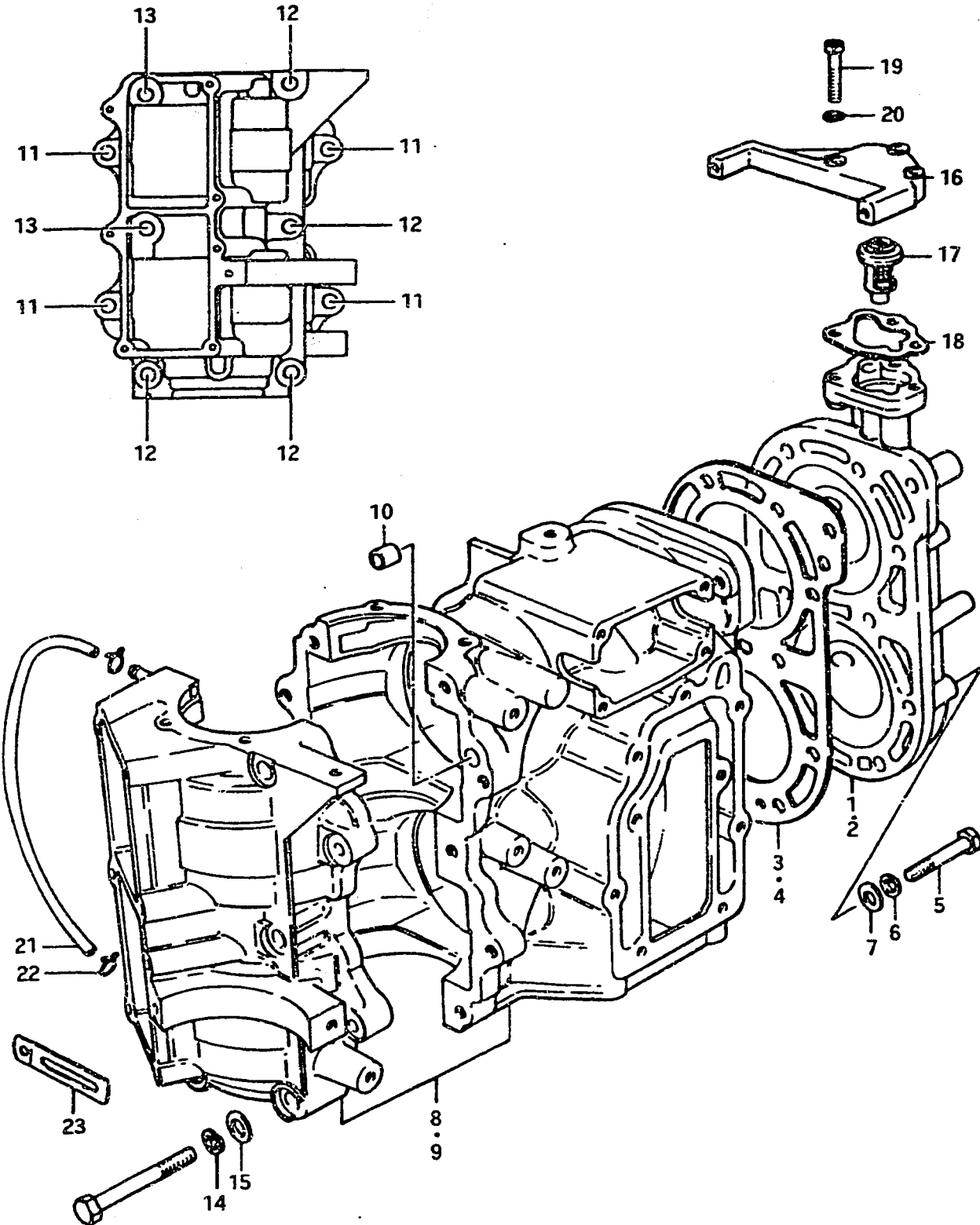

Q'ty

Ref. No.	Part No.	Description	C	D	F	Remarks
1	11110-93000-01J	CYLINDER HEAD (DT20)	1	1	1	
2	11110-93300-01J	CYLINDER HEAD (DT25,DT28)	1	1	1	to 11110-93301-01J
3	11141-93000	GASKET, cylinder head (DT20)	1	1	1	
4	11141-93300	GASKET, cylinder head (DT25,DT28)	1	1	1	to 11141-93301
5	01107-08508	BOLT	11	11	11	
6	08322-11088	WASHER	11	11	11	
7	08321-21088	LOCK WASHER	11	11	11	
8-1	11300-93850-01J	CYLINDER/CRANKCASE ASSY	1	-	-	to 11300-93851-01J
8-2	11300-93851-01J	CYLINDER/CRANKCASE ASSY	-	1	-	to 11300-93852-01J
8-3	11300-93852-01J	CYLINDER/CRANKCASE ASSY	-	1	-	to 11300-93853-01J
8-4	11300-93853-01J	CYLINDER/CRANKCASE ASSY	-	-	1	to 11300-93854-01J
8-5	11300-93854-01J	CYLINDER/CRANKCASE ASSY	-	-	1	DT20
9-1	11300-93841-01J	CYLINDER/CRANKCASE ASSY	1	1	-	from 11300-93840-01J
9-2	11300-93842-01J	CYLINDER/CRANKCASE ASSY	-	1	-	from 11300-93841-01J to 11300-93843-01J
9-3	11300-93843-01J	CYLINDER/CRANKCASE ASSY	-	-	1	to 11300-93844-01J
9-4	11300-93844-01J	CYLINDER/CRANKCASE ASSY	-	-	1	DT25,DT28F
10	04211-09109	DOWEL PIN	2	2	2	
11	01107-08358	BOLT	4	4	4	
12	01107-08558	BOLT	4	4	4	
13	01107-08458	BOLT	2	2	2	
14	08321-21088	LOCK WASHER	10	10	10	
15	08322-11088	WASHER	9	9	9	
16	17681-93300-01J	COVER, thermostat	1	1	1	
17	17670-93020	THERMOSTAT	1	1	1	
18	17685-93000	GASKET, thermostat	1	1	1	
19	01107-06308	BOLT	3	3	3	
20	08321-21068	LOCK WASHER	3	3	3	
21	09343-03016	HOSE, lubrication (L:235)	1	1	1	
22-1	09401-06401	CLIP	2	2	-	to 09401-06403
22-2	09401-06403	CLIP	-	-	2	
23	09404-06402	CLAMP, lubrication hose (L:60)	-	1	1	to 09404-06412

DT20, DT25, DT28F

DT20, DT25, DT28F

FIG. 28

G - 3

FIG. 28 EXHAUST COVER

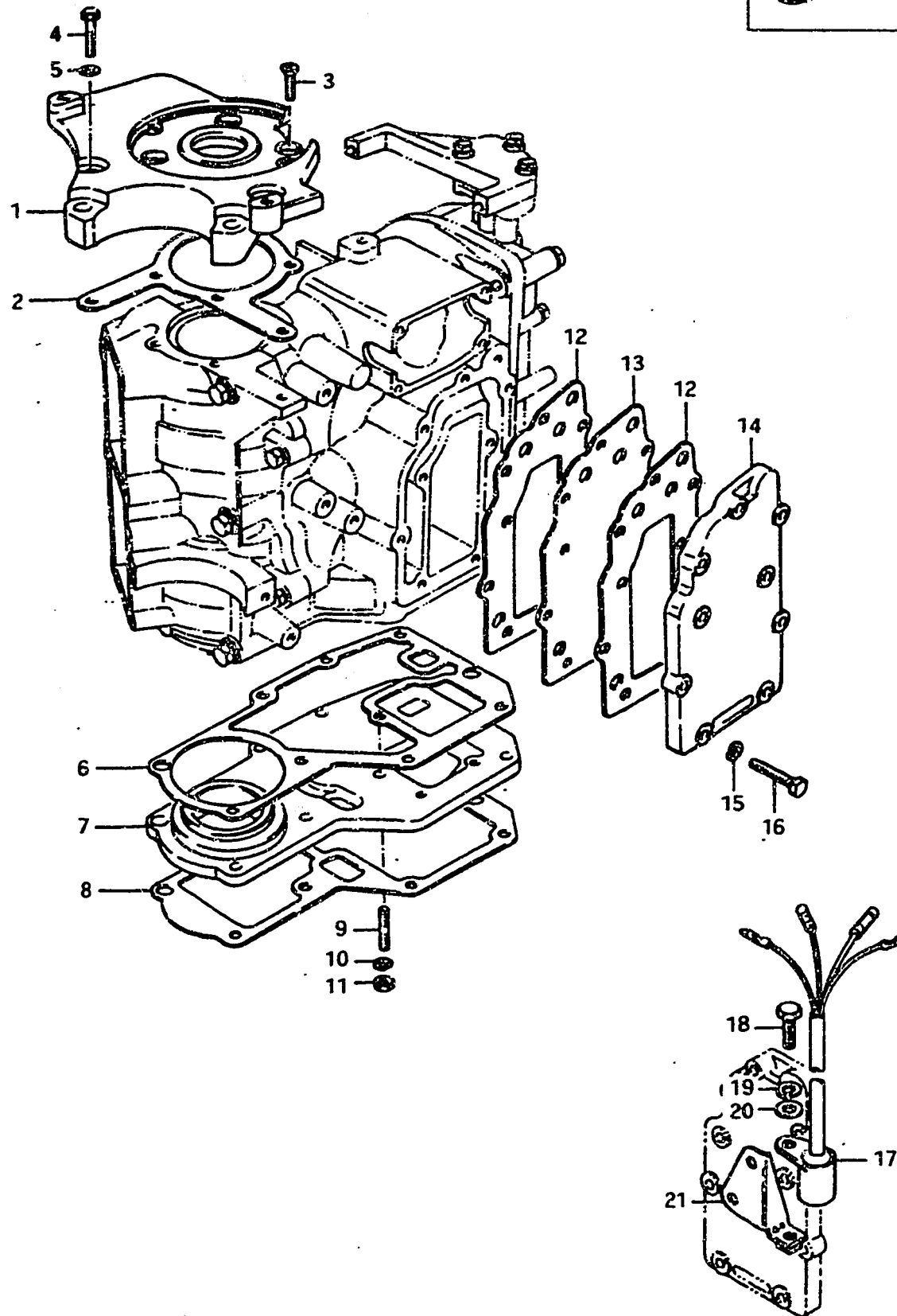

Ref. No.	Part No.	Description	Q'ty			Remarks
			C	D	F	
1-1	11411-93300-01J	HOUSING, upper oil seal	1	-	-	to 11411-93301-01J
1-2	11411-93301-01J	HOUSING, upper oil seal	-	1	1	to 11411-93302-01J
1-3	11411-93302-01J	HOUSING, upper oil seal	-	-	1	
2	11413-93300	GASKET, upper oil seal	1	1	1	
3-1	02122-06208	SCREW	4	4	-	
3-2	02122-06168	SCREW	-	-	4	
4	01107-06208	BOLT	2	2	2	
5	08321-21068	LOCK WASHER	2	2	2	
6	11433-93000	GASKET, lower oil seal housing	1	1		
7-1	11453-93000	PLATE, lower oil seal housing	1	1	-	from 11453-93000-01J
7-2	11453-93400	PLATE, lower oil seal housing	-	-	1	
8-1	52113-93000	GASKET, driveshaft housing	1	1	-	to 52113-93400
8-2	52113-93400	GASKET, driveshaft housing	-	-	1	
9	09108-06032	STUD BOLT (6x20)	1	1	1	
10	09162-06001	LOCK WASHER	1	1	1	
11	09140-06004	NUT	1	1	1	
12	14151-93000	GASKET, exhaust cover	2	2	2	
13	14131-93000	PLATE, exhaust cover	1	1	1	
14-1	14141-93000-01J	COVER, exhaust	1	1	-	to 14141-93001-01J
14-2	14141-93001-01J	COVER, exhaust	-	1	1	
15	08321-21068	LOCK WASHER	9	9	9	
16	01107-06308	BOLT, exhaust cover	9	9	9	
17	37320-93100	SWITCH ASSY, neutral interlock	-	-	1	
18	01107-06168	BOLT	-	-	1	E3 (for Hand Starter)
19	08321-21068	LOCK WASHER	-	-	1	
20	08322-21068	WASHER	-	-	1	
21	37321-93301	STAY, neutral interlock switch	-	-	1	from 37321-93300

FIG. 29

G - 4

FIG. 29 CRANKSHAFT

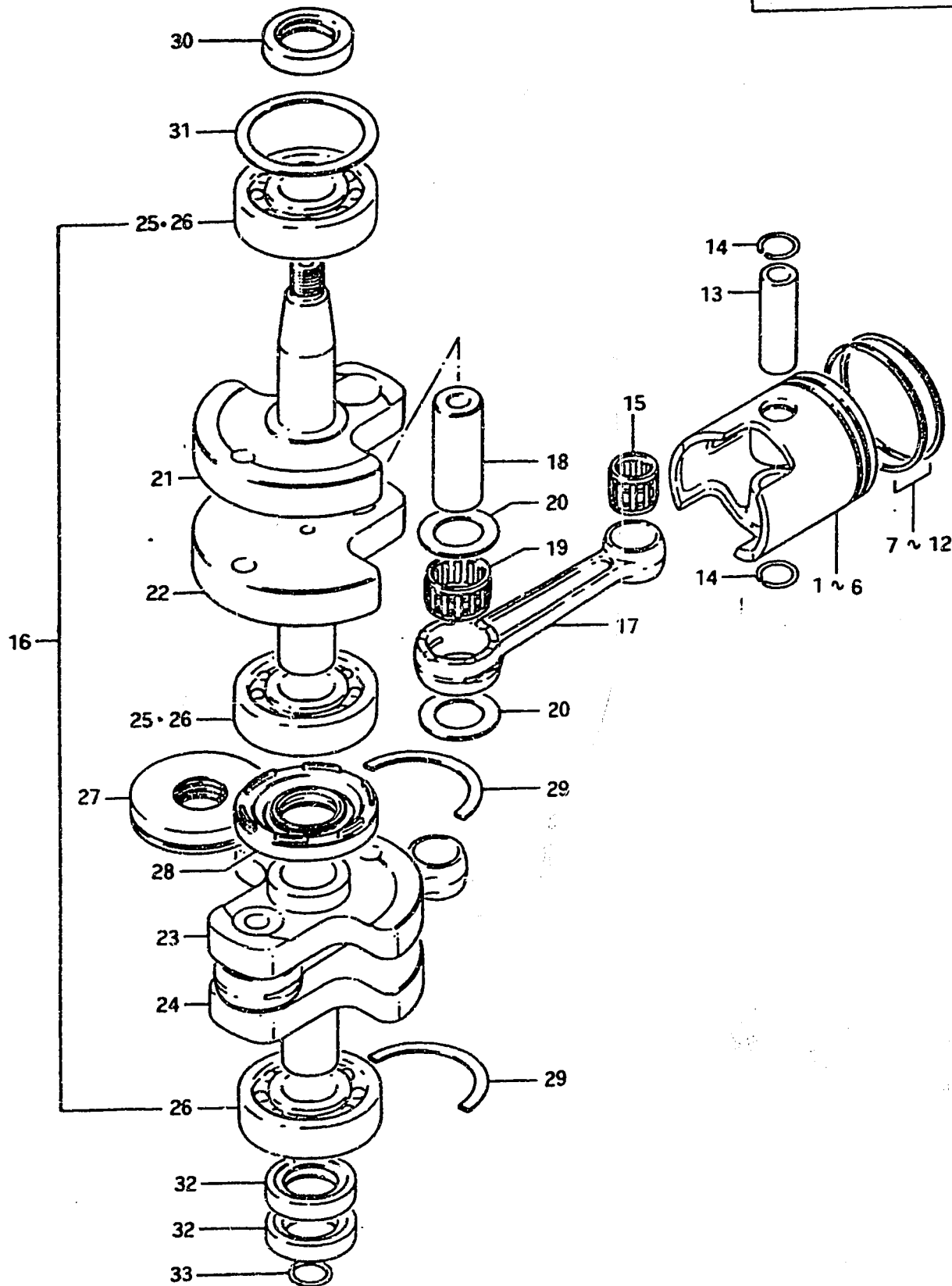

Ref. No.	Part No.	Description	Q'ty			Remarks
			C	D	F	
1-1	12110-93001	PISTON (to 12110-93002)	2	2	-	STD
1-2	12110-93002	PISTON	-	-	2	
2-1	12110-93700	PISTON (to 12110-93001-025)	2	2	-	OS:0.25, OPT
2-2	12110-93001-025	PISTON (to 12110-93002-025)	-	2	-	
2-3	12110-93002-025	PISTON	-	-	2	DT20
3-1	12110-93710	PISTON (to 12110-93001-050)	2	2	-	
3-2	12110-93001-050	PISTON (to 12110-93002-050)	-	2	-	
3-3	12110-93002-050	PISTON	-	-	2	DT25 DT28
4-1	12110-93300	PISTON (to 12110-93301)	2	2	-	
4-2	12110-93301	PISTON (to 12110-93302)	-	2	-	
4-3	12110-93302	PISTON	-	-	2	OS:0.25, OPT
5-1	12110-93720	PISTON (to 12110-93300-025)	2	2	-	
5-2	12110-93300-025	PISTON (to 12110-93301-025)	-	2	-	
5-3	12110-93301-025	PISTON (to 12110-93302-025)	-	2	-	OS:0.5, OPT
5-4	12110-93302-025	PISTON	-	-	2	
6-1	12110-93730	PISTON (to 12110-93300-050)	2	2	-	OS:0.5, OPT
6-2	12110-93300-050	PISTON (to 12110-93301-050)	-	2	-	
6-3	12110-93301-050	PISTON (to 12110-93302-050)	-	2	-	STD
6-4	12110-93302-050	PISTON	-	-	2	
7	12140-29010	RING SET, piston	2	2	2	OS:0.25, OPT
8-1	12140-93700	RING SET, piston (to 12140-29010-025)	2	2	-	
8-2	12140-29010-025	RING SET, piston	-	2	2	OS:0.5, OPT
9-1	12140-29710	RING SET, piston (to 12140-29010-050)	2	2	-	
9-2	12140-29010-050	RING SET, piston	-	2	2	
10-1	12140-93300	RING SET, piston (to 12140-93301)	1	1	-	STD
10-2	12140-93301	RING SET, piston	-	2	2	
11-1	12140-93720	RING SET, piston (to 12140-93301-050)	1	1	-	OS:0.25, OPT
11-2	12140-93301-025	RING SET, piston	-	2	2	
12-1	12140-93730	RING SET, piston (to 12140-93301-050)	1	1	-	OS:0.5, OPT
12-2	12140-93301-050	RING SET, Piston	-	2	2	
13	12151-93300	PIN, piston	2	2	2	
14	09381-16001	CIRCLIP, piston pin	4	4	4	
15	09263-16010	BEARING, piston pin	2	2	2	to 09263-16015

FIG.29

G - 5

FIG.29 CRANKSHAFT

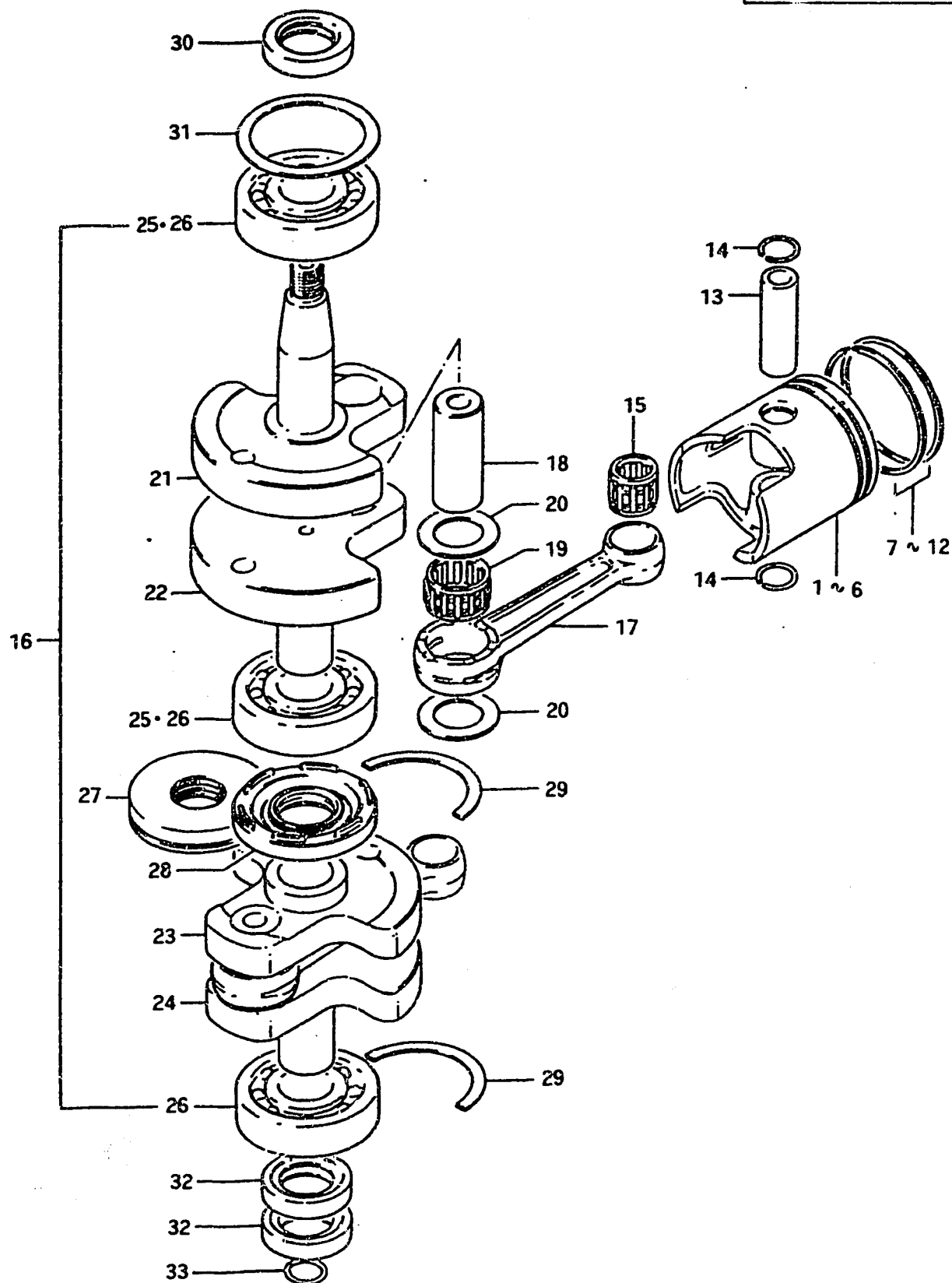

Ref. No.	Part No.	Description	Q'ty			Remarks
			C	D	F	
16-1	12200-93822	CRANKSHAFT ASSY	1	-	-	to 12200-93823
16-2	12200-93823	CRANKSHAFT ASSY	-	1	-	to 12200-93824
16-3	12200-93824	CRANKSHAFT ASSY DT20D-11974~,DT25D-13643~	-	1	-	to 12200-93825
16-4	12200-93826	CRANKSHAFT ASSY	-	1	-	from 12200-93825
16-5	12200-93831	CRANKSHAFT ASSY ~DT20F-11285,~DT25F-10784	-	-	1	to 12200-93832
16-6	12200-93401	CRANKSHAFT ASSY	-	-	1	from 12200-93832
17-1	12161-93000	•ROD, conecting to (12161-93990)+(09263-22027)	2	2	-	
17-2	12161-93401	•ROD, conecting	-	-	2	
18	12211-93001	•PIN, crank	2	2	2	
19-1	09263-22006	•BEARING, crank pin	2	2	-	22x28x16 to 09263-22024
19-2	09263-22024	•BEARING, crank pin	-	2	-	22x28x17
19-3	09263-22026	•BEARING, crank pin	-	-	2	22x29x16 to 09263-22027
20	09160-22010	•THRUST WASHER	4	4	4	22x35x1
21	12221-93002	•CRANKSHAFT, upper	1	1	1	
22	12231-93001	•CRANKSHAFT, middle	1	1	1	
23	12232-93001	•CRANK WHEEL	1	1	1	
24-1	12240-93001	•CRANKSHAFT, lower	1	1	-	
24-2	12240-93400	•CRANKSHAFT, lower	-	-	1	
25	09262-25054	•BEARING, crank	-	-	2	25x62x17
26	09262-25033	•BEARING, crankshaft	3	3	1	25x62x17
27	12321-93001	•SEAL, labyrinth	1	-	-	to 09289-25003
28-1	09289-25003	•OIL SEAL (25x62x8x11)	-	1	-	to 09289-25009
28-2	09289-25009	•OIL SEAL (25x62x8x10) DT20D-11974~, DT25D-13643~	-	1	1	
29	09390-52004	C RING	2	2	1	
30	09283-25035	OIL SEAL, upper crankshaft	1	1	1	25x40x7
31	09181-50004	SHIM, upper crankshaft		AR		50x61x0.5
32	09283-25070	OIL SEAL, lower crankshaft	2	2	1	25x38x8 from 09283-25031
33	09280-15002	O RING, lower crankshaft	1	1	-	d:1.9, ID:14.5

FIG. 30

G - 6

FIG.30 REED VALVE

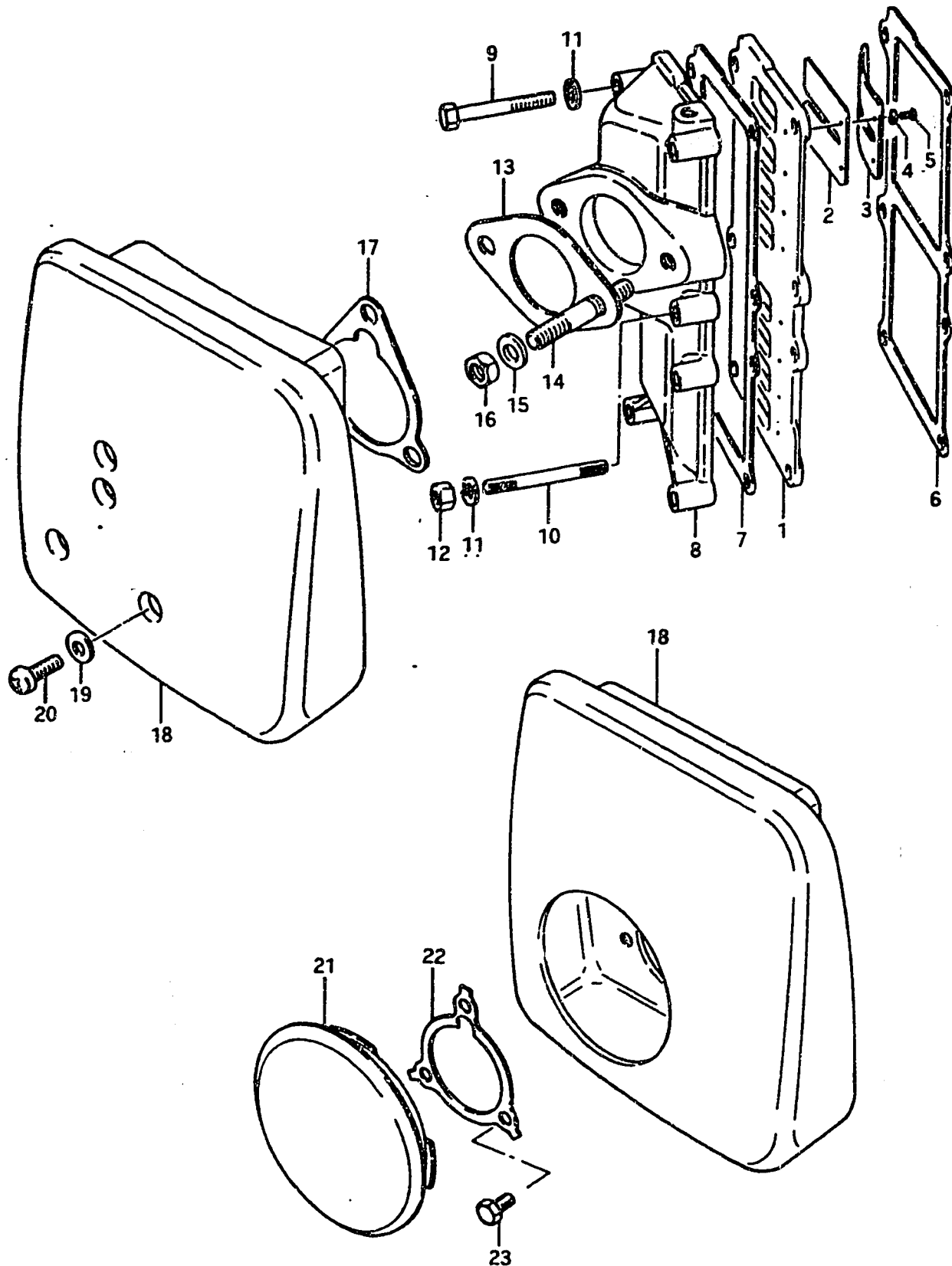

Ref. No.	Part No.	Description	Q'ty			Remarks
			C	D	F	
1-1	13150-93310	VALVE ASSY, reed	1	1	1	to 13150-93311
1-2	13150-93311	VALVE ASSY, reed	-	-	1	to 13150-93312
2	13153-93310	·VALVE, reed	4	4	4	
3	13152-93310	·STOPPER, reed valve	4	4	4	
4	08321-21038	·LOCK WASHER	8	8	8	
5	02112-03068	·SCREW	8	8	8	
6-1	13122-93300	GASKET, valve sheet	1	1	1	to 13122-93301
6-2	13122-93301	GASKET, valve sheet DT20F-11600~,DT25F-12130~	-	-	1	
7	13121-93300	GASKET, inlet case	1	1	1	
8-1	12481-93300-01J	CASE, inlet	1	1	-	
8-2	12481-93400-01J	CASE, inlet	-	-	1	to 12481-93401-01J
8-3	12481-93401-01J	CASE, inlet DT20F-11600~,DT25F-12130~	-	-	1	
9	01107-06358	BOLT	5	5	5	
10	01421-06308	STUD BOLT	2	2	2	
11	08321-21068	LOCK WASHER	7	7	7	
12	08310-22068	NUT	2	2	2	
13	13125-93000	GASKET, carburetor	1	1	1	
14	01411-08208	STUD BOLT	2	2	2	
15	08322-11088	WASHER	2	2	2	
16	08310-22088	NUT	2	2	2	
17	13855-93300	GASKET, silencer	1	1	1	
18-1	13811-93300	SILENCER to (13811-93301)+(09250-88001)+(13912-93300)+(01107-06128)	1	1	-	
18-2	13811-93301	SILENCER	-	-	1	
19	08322-11068	WASHER	3	3	-	
20	02112-06128	SCREW	3	3	-	
21	09250-88001	CAP, silencer	-	-	1	
22	13912-93300	PLATE, silencer	-	-	1	to 13912-93301
23	01107-06128	BOLT	-	-	3	

FIG.31

G - 7

FIG.31 CARBURETOR (DT20)

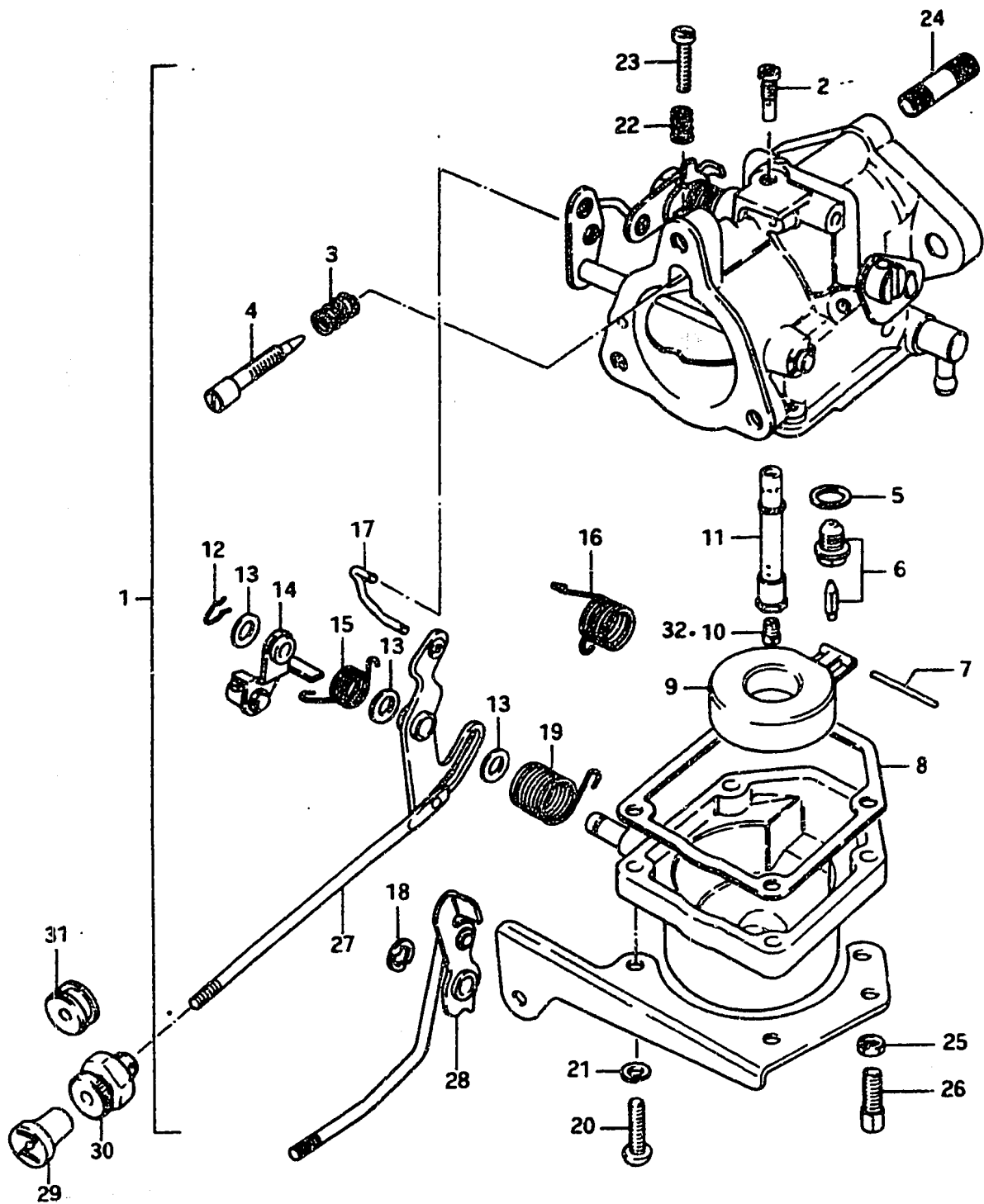

Q'ty



Ref. No.	Part No.	Description	C	D	F	Remarks
1-1	13200-93613	CARBURETOR ASSY (stamp:613)	1	-	-	L,LL & UL type
1-2	13200-93620	CARBURETOR ASSY (stamp:620)	1	-	-	S type to 13200-93621
1-3	13200-93621	CARBURETOR ASSY (stamp:621)	-	1	-	to 13200-93622
1-4	13200-93622	CARBURETOR ASSY (stamp:622)	-	1	-	~DT20D-12055 to 13200-93623
1-5	13200-93623	CARBURETOR ASSY (stamp:93623)	-	1	-	
1-6	13200-93641	CARBURETOR ASSY (stamp:93641)	-	-	1	
2-1	09492-70001	•JET, pilot (70)	1	-	-	
2-2	09492-62001	•JET, pilot (62.5)	-	1	1	
3-1	13271-93310	•SPRING, air screw	1	1	-	
3-2	13271-93311	•SPRING, air screw	-	-	1	
4-1	13269-93310	•SCREW, pilot air (stamp:~621)	1	1	-	 to 13269-93311
4-2	13269-93311	•SCREW, pilot air (stamp:622~)	-	1	1	
5	13392-58600	•GASKET, needle valve	1	1	1	
6	13370-28110	•VALVE ASSY, needle	1	1	1	
7	13254-93010	•PIN, float	1	1	1	
8	13251-93310	•GASKET, float chamber	1	1	1	
9-1	13250-93011	•FLOAT	1	1	-	
9-2	13250-93012	•FLOAT	-	-	1	
10-1	09491-26009	•JET, main (130)	1	-	-	L,LL & UL type
10-2	09491-25002	•JET, main (~stamp 622)	*1	1	-	*S type,125
10-3	09491-26009	•JET, main (stamp:93623~)	-	1	1	130,DT20D-12056~
11	13235-95210	•NOZZLE	1	1	1	
12	13415-95210	•CLIP	1	1	1	
13	13E89-95210	•WASHER, choke lever	3	3	3	

FIG.32 (G-9, 10) : DT25, DT28



FIG.31

G - 8

FIG.31 CARBURETOR (DT20)

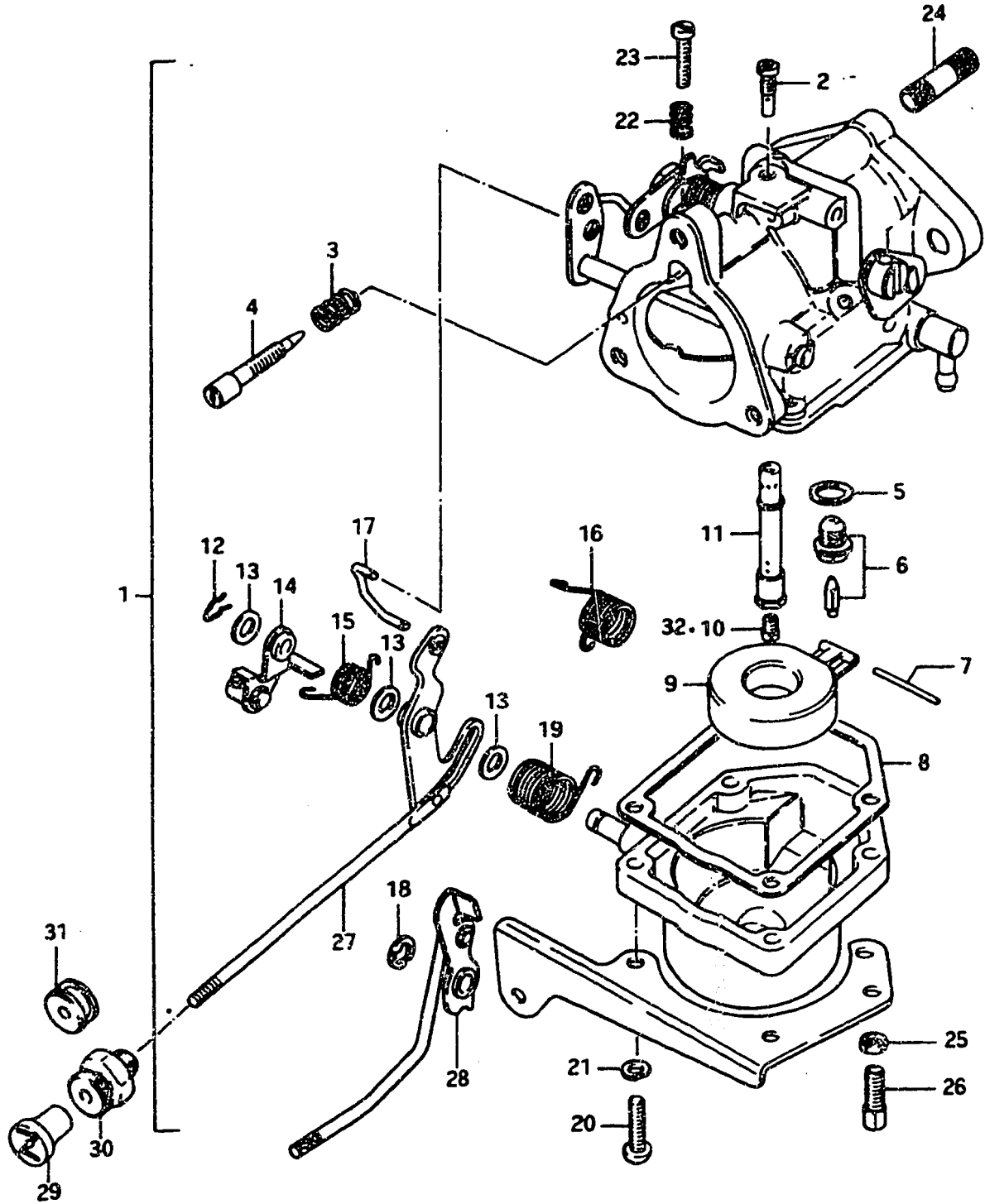

Ref. No.	Part No.	Description	Q'ty			Remarks
			C	D	F	
14	13414-93310	•LEVER ASSY, choke 1	1	1	-	
15	13417-93310	•SPRING, choke lever	1	1	-	
16	13573-93310	•SPRING	-	-	1	
17	13594-93310	•ROD, choke	1	1	-	
18	13593-93400	•E RING	-	-	1	
19	13592-93310	•SPRING, choke lever	1	1	-	
20	02112-05208	•SCREW	4	4	4	
21	08321-21058	•LOCK WASHER	4	4	4	
22-1	13268-95210	•SPRING, stop screw	1	1	-	to 13268-96110
22-2	13268-96110	•SPRING, stop screw	-	-	1	
23-1	13267-95210	•SCREW, throttle stop	1	1	-	
23-2	13267-96111	•SCREW, throttle stop	-	-	1	
24	01411-08208	•STUD BOLT	-	-	1	
25	13661-03010	•NUT, throttle cable adjust	1	1	-	
26	13577-15010	•ADJUSTER, throttle cable	1	1	-	from 13577-22600
27	13413-93310	•LEVER ASSY, choke 2	1	1	-	
28	13413-93400	•LEVER ASSY	-	-	1	
29	13631-99002	KNOB, choke (M4)	1	1	1	to 13631-93500
30	13640-93300	ADJUSTER ASSY, choke	1	1	-	
31	09308-03003	GROMMET	-	-	1	
32-1	09491-24012	JET, main (120)	1	1	1	} OPT
32-2	09491-27008	JET, main (135)	1	1	1	
32-3	09491-27006	JET, main (115)	1	1	1	

FIG.32 (G-9, 10) : DT25, DT28

FIG. 32

G - 9

FIG. 32 CARBURETOR (DT25,DT28)

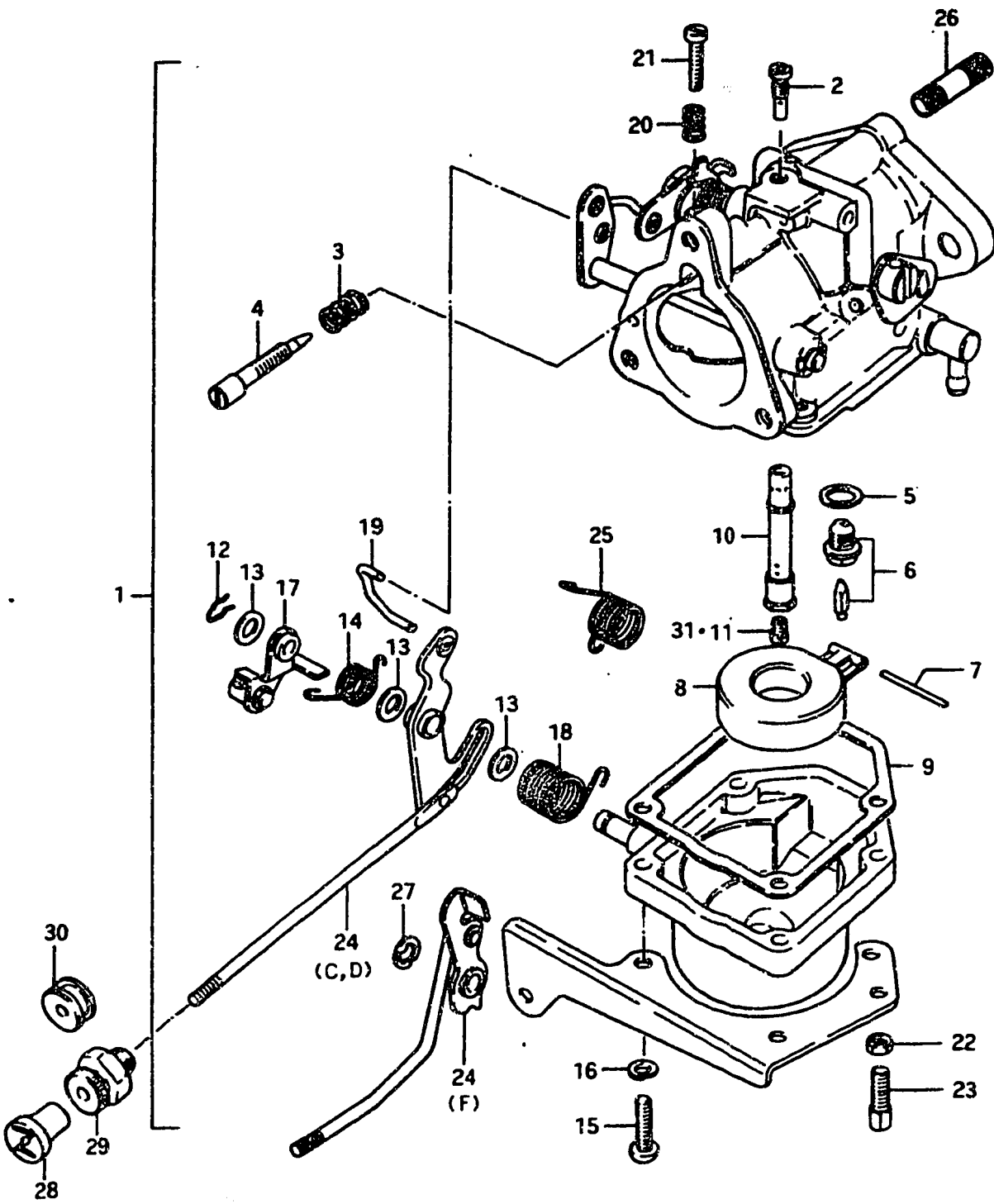

Q'ty



Ref. No.	Part No.	Description	C	D	F	Remarks
1-1	13200-93310	CARBURETOR ASSY (stamp:310)	1	1	-	to 13200-93311 ~DT25D-11010
1-2	13200-93311	CARBURETOR ASSY (stamp:311)	-	1	-	to 13200-93312 ~DT25D-14204
1-3	13200-93312	CARBURETOR ASSY (stamp:93312)	-	1	-	DT25D-14205~
1-4	13200-93411	CARBURETOR ASSY (stamp:93411)	-	-	1	
2-1	09492-60005	·JET, pilot (60)	1	-	-	
2-2	09492-70001	·JET, pilot (70)	-	1	-	
2-3	09492-75001	·JET, pilot (75)	-	-	1	
3-1	13271-93310	·SPRING, air screw	1	1	-	
3-2	13271-93311	·SPRING, air screw	-	-	1	
4-1	13269-93310	·SCREW, pilot air 	1	1	-	to 13269-93311
4-2	13269-93311	·SCREW, pilot air 	-	1	1	DT25D-14205~
5	13392-58600	·GASKET, needle valve	1	1	1	from 13392-18110
6	13370-28110	·VALVE ASSY, needle	1	1	1	
7	13254-93010	·PIN, float	1	1	1	
8-1	13250-93011	·FLOAT	1	1	-	
8-2	13250-93012	·FLOAT	-	-	1	
9	13251-93310	·GASKET, float chamber	1	1	1	
10	13235-95210	·NOZZLE	1	1	1	
11-1	09491-31003	·JET, main (155)	1	1	-	
11-2	09491-32006	·JET, main (160)	-	-	1	
12	13415-95210	·CLIP	1	1	1	
13	13589-95210	·WASHER, choke lever	3	3	3	
14	13417-93310	·SPRING, choke lever	1	1	-	
15	02112-05208	·SCREW	4	4	4	
16	08321-21058	·LOCK WASHER	4	4	4	
17	13414-93310	·LEVER ASSY, choke 1	1	1	-	
18	13592-93310	·SPRING, choke lever	1	1	-	
19	13594-93310	·ROD, choke	1	1	-	
20-1	13268-95210	·SPRING, stop screw	1	1	-	to 13268-96110
20-2	13268-96110	·SPRING, stop screw	-	-	1	
21-1	13267-95210	·SCREW, throttle stop	1	1	-	
21-2	13267-96111	·SCREW, throttle stop	-	-	1	

FIG. 31 (G-7, 8) : DT20

FIG.32

G - 10

FIG.32 CARBURETOR (DT25,DT28)

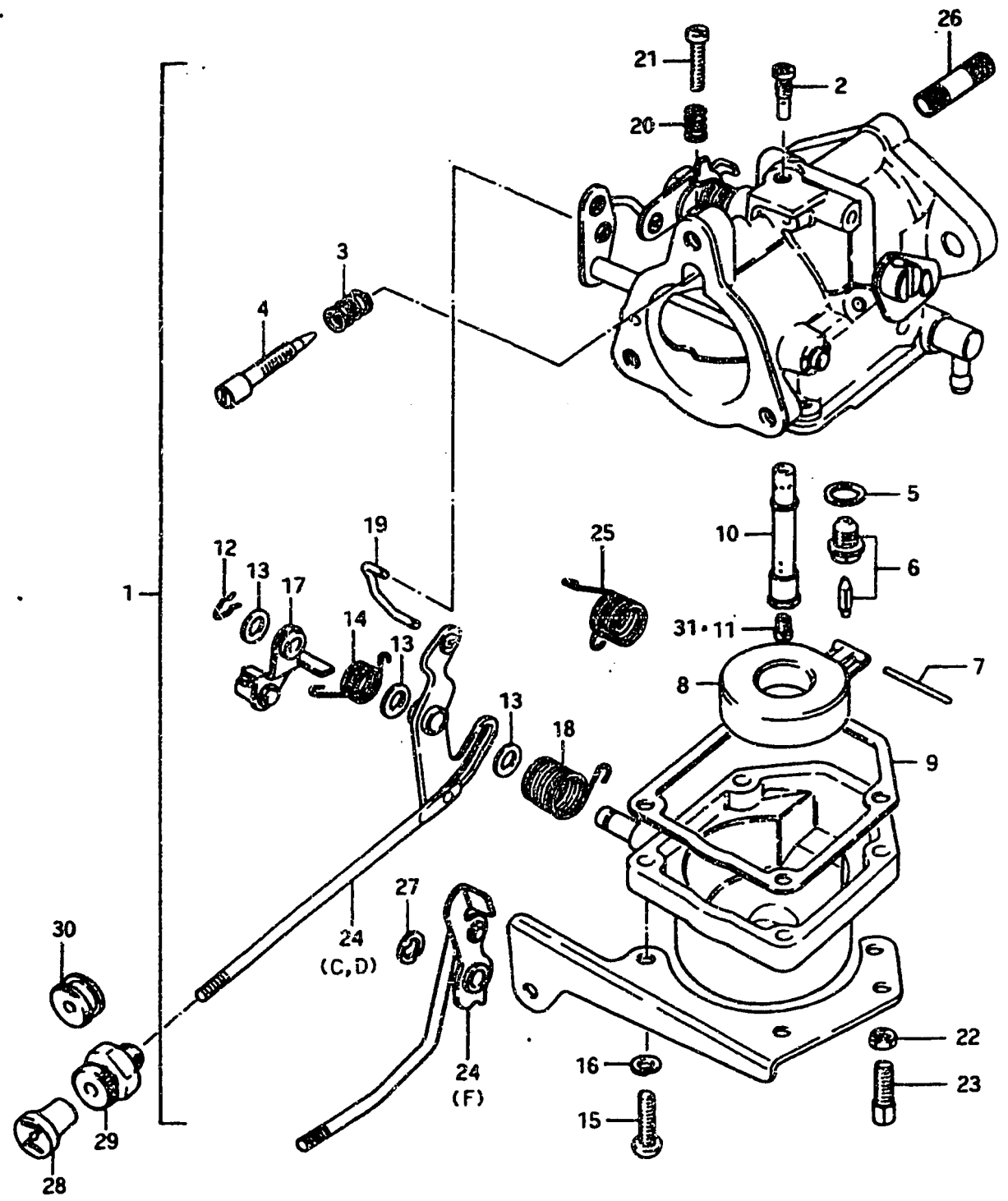

Ref. No.	Part No.	Description	Q'ty			Remarks
			C	D	F	
22	13651-03010	·NUT, throttle cable adjust	1	1	-	
23	13577-15010	·ADJUSTER, throttle cable	1	1	-	from 13577-22600
24-1	13413-93310	·LEVER ASSY, choke 2	1	1	-	
24-2	13413-93400	·LEVER ASSY, choke 2	-	-	1	
25	13573-93310	·SPRING	-	-	1	
26	01411-08208	·STUD BOLT	-	-	1	
27	13593-93400	·E RING	-	-	1	
28	13631-99002	·KNOB, choke	1	1	1	to 13631-93500
29	13640-93300	ADJUSTER ASSY, choke	1	1	-	
30	09308-03003	GROMMET, carburetor	-	-	1	
31-1	09491-30008	JET, main (150)	1	1	1	} OPT
31-2	09491-29007	JET, main (145)	1	1	1	
31-3	09491-33001	JET, main (165)	1	1	1	

FIG.31 (G-7, 8) : DT20

FIG.33

G - 11

FIG.33 FUEL PUMP

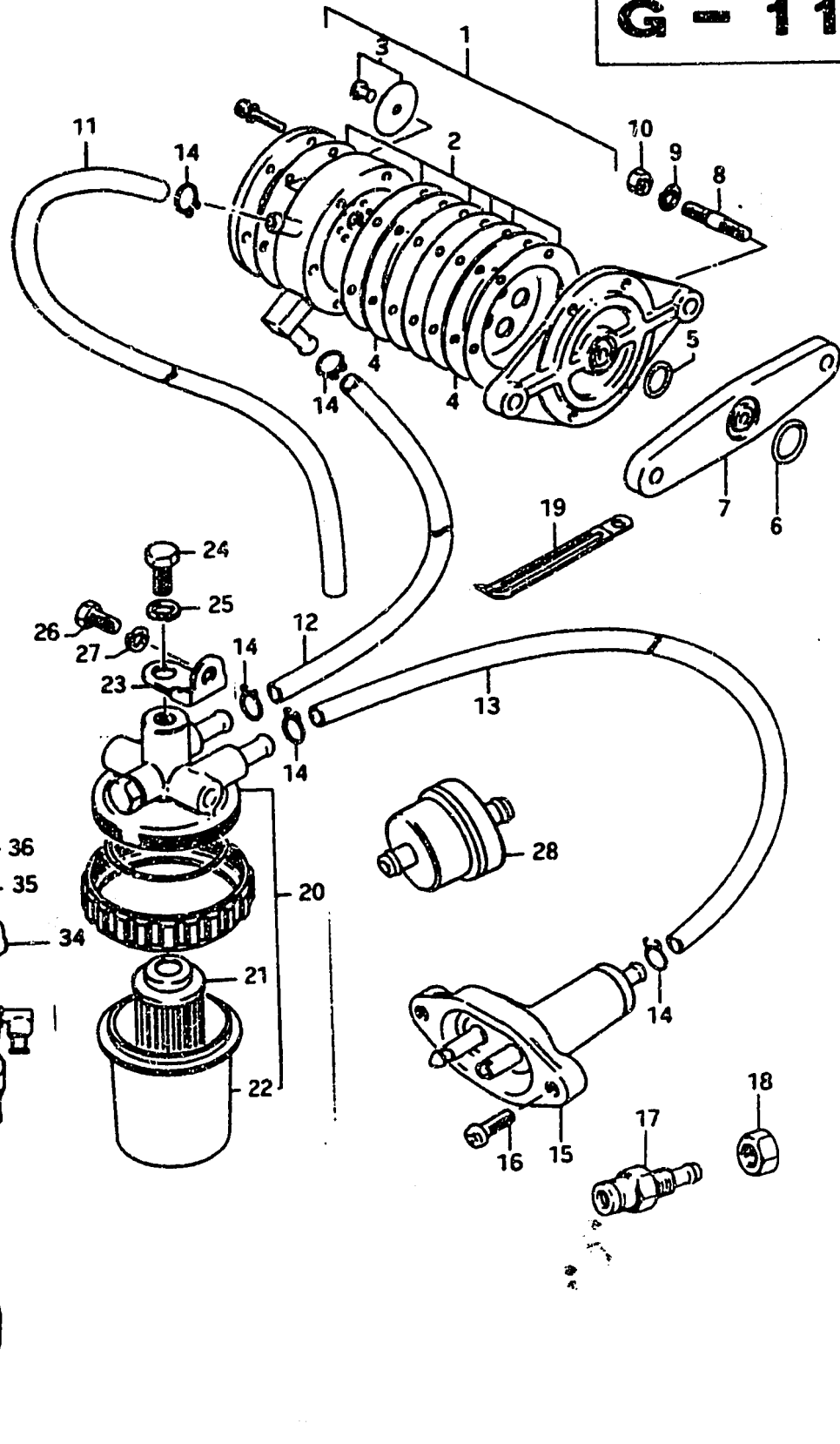

Ref. No.	Part No.	Description	Q'ty			Remarks
			C	D	F	
1-1	15100-93310	PUMP ASSY, fuel	1	1	-	
1-2	15100-93410	PUMP ASSY, fuel	-	-	1	
2	15170-93810	DIAPHRAGM SET	1	1	1	
3	15180-93810	VALVE SET	1	1	1	
4	15162-93010	STOPPER, diaphragm	2	2	2	
5	15165-93010	O RING	1	1	1	
6	09280-12002	O RING, fuel pump	1	1	1	d:2.4, ID:11.8
7	15322-93000	INSULATOR, fuel pump	1	1	1	
8	01421-06258	STUD BOLT	2	2	2	
9	08321-21068	LOCK WASHER	2	2	2	
10	08310-11068	NUT	2	2	2	
11-1	09343-05143	HOSE (pump→carbu)	1	-	-	to 09343-05137 L:270
11-2	09343-05137	HOSE (pump→carbu)	1	1	-	L:500→270
11-3	09343-05137	HOSE (pump→carbu)	-	-	1	L:500→350
12-1	09343-05137	HOSE (fillter→pump)	1	1	-	L:500→240
12-2	09343-05137	HOSE (fillter→pump)	-	-	1	L:500→110
12-3	09343-05137	HOSE (fillter→pump)	-	-	1	L:500→135 (E13)
13-1	09343-05137	HOSE (connector→filter)	1	1	-	L:500
13-2	09343-05137	HOSE (connector→filter)	-	-	1	L:500→270
13-3	09343-05137	HOSE (connector→filter)	-	-	1	L:500 (E13)
14-1	09401-08401	CLIP	6	6	-	
14-2	09401-09402	CLIP	-	-	6	
15	65700-96811-01J	PLUG SET, fuel connector	1	1	-	
16-1	02112-05168	SCREW	2	-	-	to 09125-05029
16-2	09125-05029	SCREW (5x16)	-	2	-	
17	65720-98500	PLUG, fuel connector	-	1	1	to 65720-98501
18	08310-22108	NUT	-	1	1	
19	09404-06415	CLAMP, fuel hose (L:95)	-	-	1	

FIG. 33

G - 12

FIG. 33 FUEL PUMP

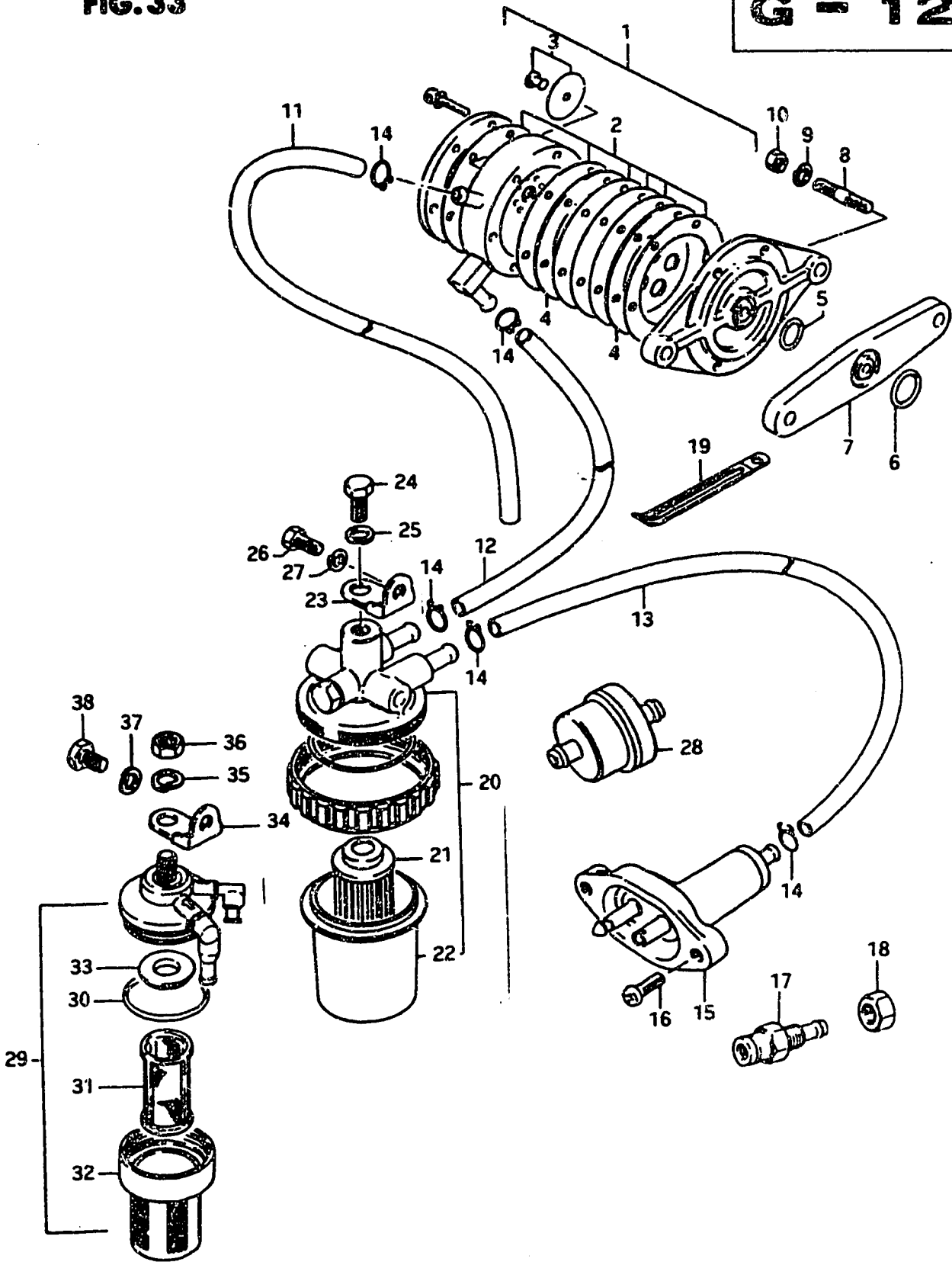

Ref. No.	Part No.	Description	Qty			Remarks
			C	D	F	
20	15410-96100	FILTER ASSY, fuel	1	1	-	
21	15412-96100	·STRAINER	1	1	-	
22	15413-96100	·CUP	1	1	-	
23-1	15421-93300	BRACKET, fuel filter	1	-	-	to 15421-93301
23-2	15421-93301	BRACKET, fuel filter	-	1	-	
24	01107-08128	BOLT	1	1	-	
25	08321-21088	LOCK WASHER	1	1	-	
26	01107-06128	BOLT	1	1	-	
27	08321-21068	LOCK WASHER	1	1	-	
28	15410-98500	FILTER ASSY, fuel	-	-	1	
29	15410-93400	FILTER ASSY	-	-	1	DT20 } E13 DT25 }
30	15415-93400	·O RING	-	-	1	
31	15412-93400	·STARINER	-	-	1	
32	15413-93400	·CUP	-	-	1	
33	15416-93400	·PACKING	-	-	1	
34	15421-93301	BRACKET, filter	-	-	1	
35	08321-21088	LOCK WASHER	-	-	1	
36	08310-22088	NUT	-	-	1	
37	08321-21068	LOCK WASHER	-	-	1	
38	01107-06128	BOLT	-	-	1	

FIG. 34

G - 13

FIG. 34 WATER PUMP

Q'ty

Ref. No.	Part No.	Description	C	D	F	Remarks
1-1	17411-93000	CASE, water pump	1	-	-	
1-2	17411-93001	CASE, water pump	-	1	1	from 17411-93000 to 17411-93002
1-3	17411-93011	CASE, water pump (E9)	-	-	1	to 17411-93012
2	09108-05003	STUD BOLT (5x23)	3	3	3	to 09108-05008
3	09140-05001	NUT	3	3	3	
4	09162-05002	LOCK WASHER	3	3	3	
5	09420-04004	KEY	1	1	1	
6	17461-93002	IMPELLER, water pump	1	1	1	from 17461-93001
7	17471-93002	PANEL, pump case lower	1	1	1	from 17471-93001
8-1	17472-93000	GASKET, pump panel	1	1	1	DT25,DT20
8-2	17472-93400	GASKET, pump panel	-	-	1	DT28F,DT25FE3
9	17561-93700	TUBE, water	1	1	1	S type,L:239
10	17561-93000	TUBE, water	1	1	1	L type,L:358
11	17561-93710	TUBE, water	1	1	1	LL type,L:409
12	17561-93720	TUBE, water	1	1	1	UL type,L:478
13-1	17431-93700	TUBE, water pump seal	1	1	-	S type,L:64
13-2	17431-93701	TUBE, water pump seal	-	-	1	S type,L:89
14-1	17431-93000	TUBE, water pump seal	1	1	-	L type,L:183
14-2	17431-93001	TUBE, water pump seal	-	-	1	L type,L:208 from 17431-93000
15	17431-93710	TUBE, water pump seal	1	1	1	LL type,L:234
16	17431-93720	TUBE, water pump seal	1	1	1	UL type,L:303
17	09280-22005	O RING, seal tube	2	2	2	d:2.4,ID:21.8
18	17400-93841	WATER PUMP RIPER KIT	-	-	1	E9

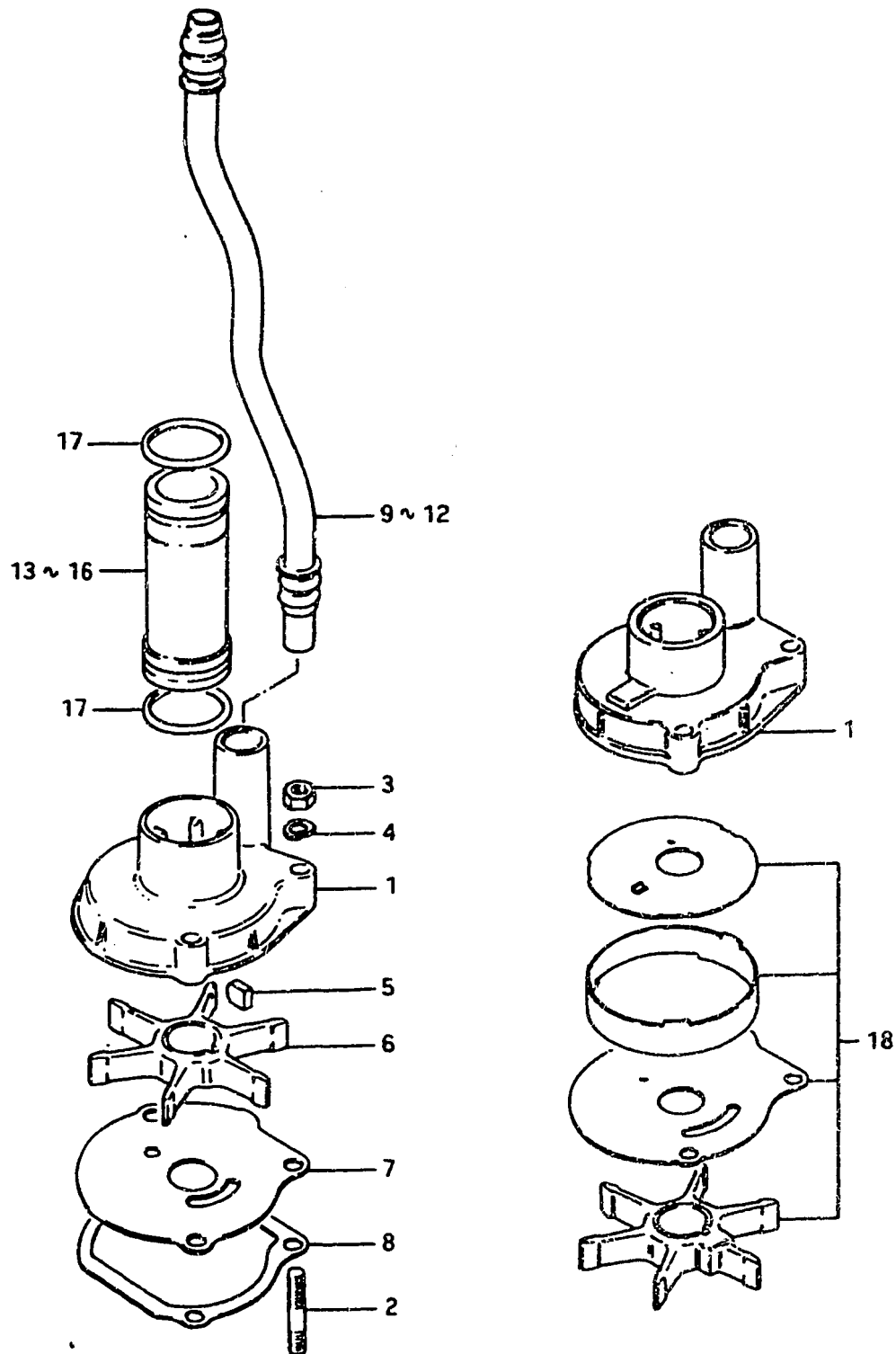
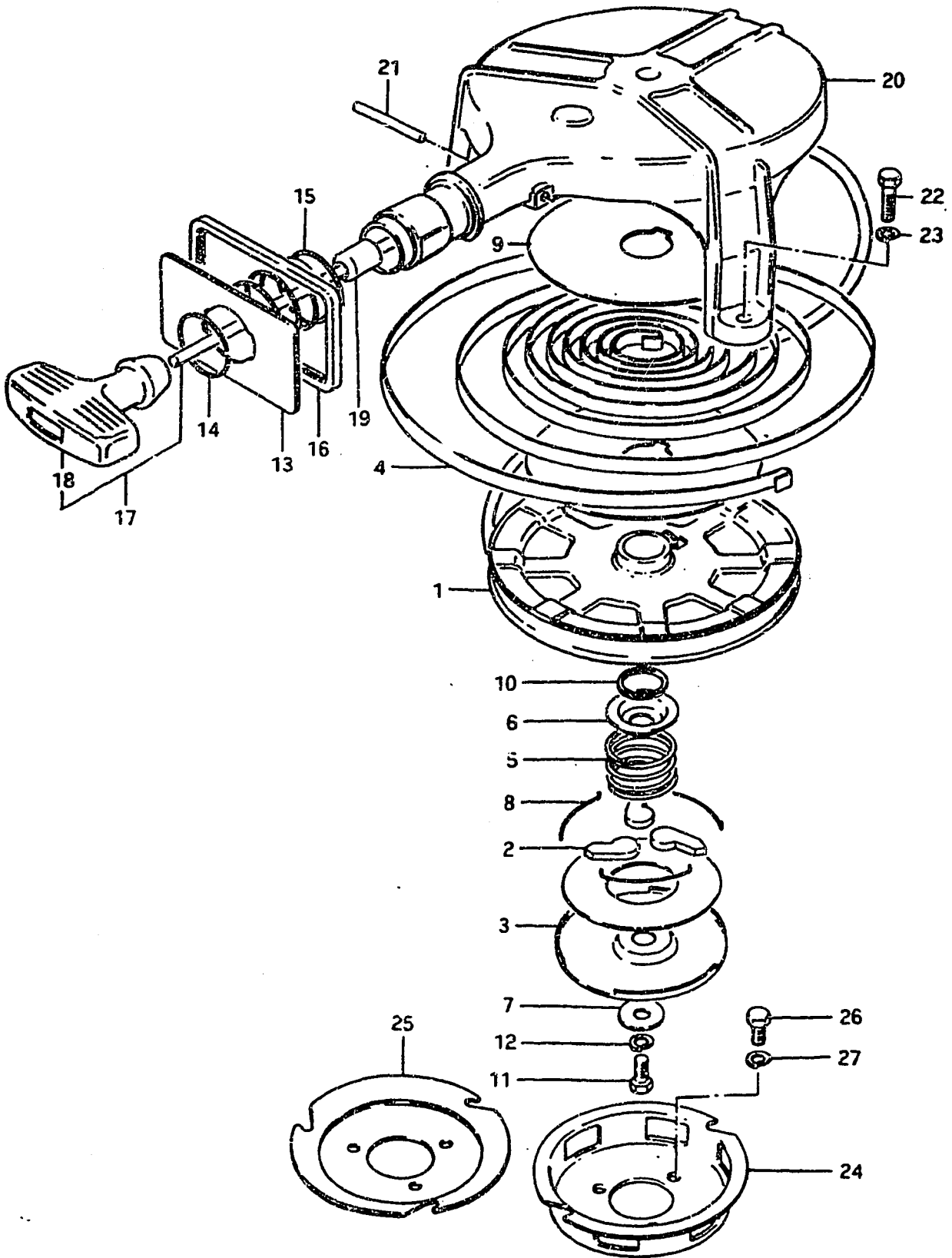

FIG. 35

G - 14

FIG.35 RECOIL STARTER



Ref. No.	Part No.	Description	Q'ty			Remarks
			C	D	F	
0-1	18100-93300	STARTER ASSY, recoil	1	-	-	DT20C-12335 to 18100-93301
0-2	18100-93301	STARTER ASSY, recoil	1	1	-	to 18100-93302
0-3	18100-93302	STARTER ASSY, recoil	-	1	-	to 18100-93303
0-4	18100-93303	STARTER ASSY, recoil	-	1	1	
1-1	18121-93300	·SHEAVE DRUM	1	-	-	to 18121-93301
1-2	18121-93301	·SHEAVE DRUM	1	1	1	
2	18131-93000	·PAWL, drive	3	3	3	
3	18151-93000	·PLATE, drive	1	1	1	
4	18142-93000	·SPRING, starter roll	1	1	1	
5	18145-93000	·SPRING	1	1	1	
6-1	18143-93000	·PLATE, spring	1	1	-	⊕ to 18143-93001
6-2	18143-93001	·PLATE, spring	-	1	1	⊕
7	18146-93000	·WASHER	1	1	1	
8	18155-93000	·SPRING, drive pawl	3	3	3	
9	18144-93000	·SPACER, roll spring	2	2	2	from 18138-93000
10	18147-93000	·WASHER, adjusting	1	1	1	
11	01107-06168	·BOLT	1	1	1	
12	08321-21068	·LOCK WASHER	1	1	1	
13	18231-93000	·PLATE, guide	1	1	1	
14	18238-93000	·CLIP, guide plate	1	1	1	
15	18236-93000	·SPRING, guide plate	1	1	1	
16	18233-93000	·RUBBER, guide plate	1	1	1	
17-1	18200-93820	·GRIP ASSY, starter	1	1	-	to 18200-93821
17-2	18200-93821	·GRIP ASSY, starter	-	1	1	
18-1	18210-93000	·GRIP	1	1	-	to 18210-93001
18-2	18210-93001	·GRIP	-	1	1	
19	18181-93000	·GUIDE, rope	1	1	1	
20-1	18111-93300	·CASE, starter to (18111-93301)+(18157-93001)	1	1	-	
20-2	18111-93301	·CASE, starter	-	-	1	
21	18185-93000	·PIN, rope guide	1	1	1	
22	01107-06258	BOLT	3	3	3	
23	08321-21068	LOCK WASHER	3	3	3	
24	18411-93000	CUP, starter	1	1	1	
25	18411-93400	PULLY, emergency	-	-	1	for Electric Starter
26	01107-06168	BOLT	3	3	3	
27	08321-21068	LOCK WASHER	3	3	3	

FIG. 36

H - 2

FIG. 36 CLUTCH LEVER

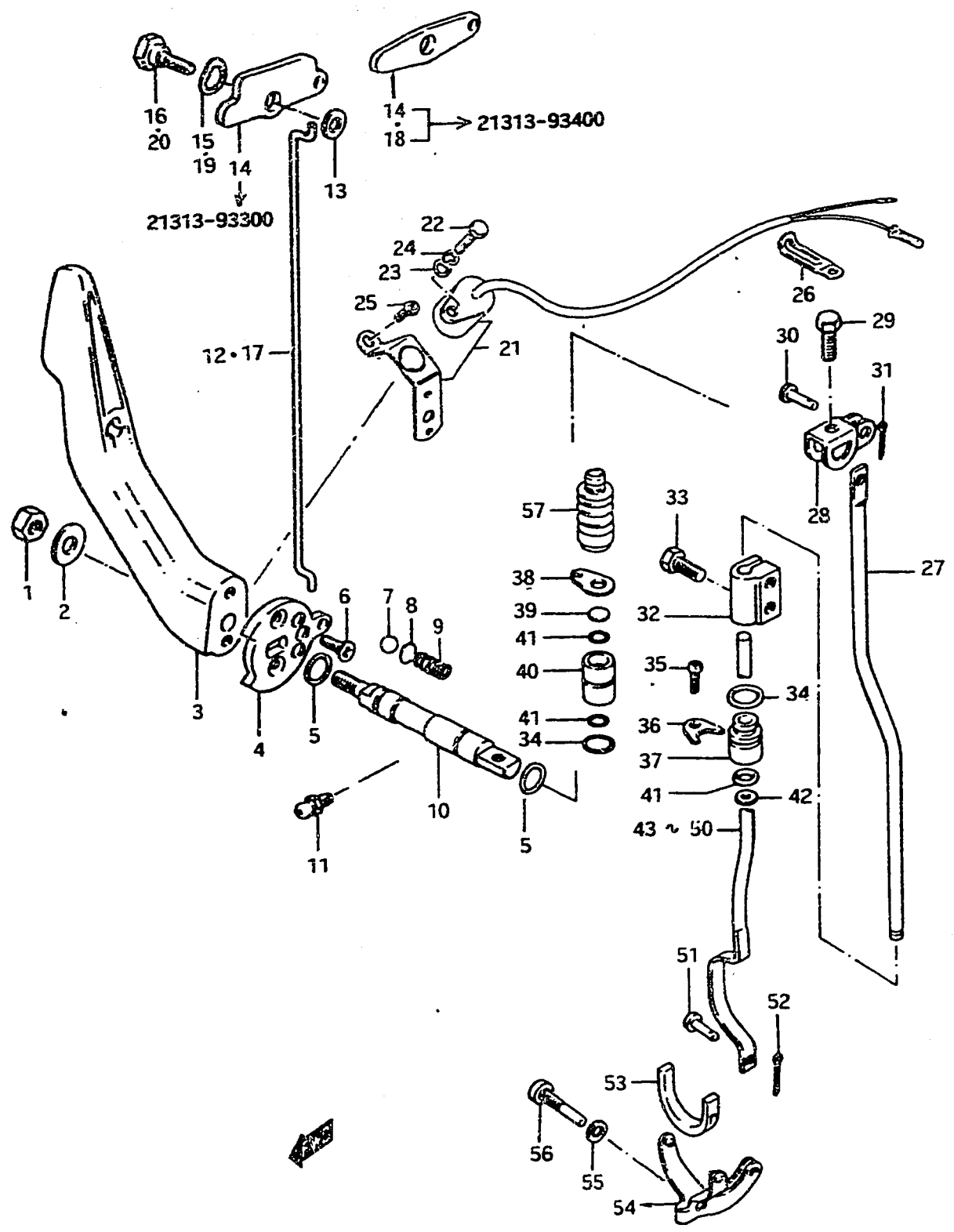

Ref. No.	Part No.	Description	Q'ty			Remarks
			C	D	F	
1-1	08319-23089	NUT	1	-	-	to 09159-08026
1-2	09159-08026	NUT	-	1	1	
2	09160-08015	WASHER (8.5x16x1.2)	1	1	1	
3-1	21111-93100-01J	LEVER, clutch	1	-	-	to 21111-93101-01J
3-2	21111-93101-01J	LEVER, clutch	-	1	-	to 21111-93102-01J
3-3	21111-93102-01J	LEVER, clutch	-	1	-	to 21111-93103-01J
3-4	21111-93103-01J	LEVER, clutch	-	1	-	to 21111-93500-01J
3-5	21111-93400-01J	LEVER, clutch	-	-	1	
4	21112-93300	PLATE, clutch lever	1	1	1	
5	09280-09003	O RING (d:1.9, ID:8.8)	2	2	2	
6	02122-04128	SCREW	2	2	2	
7	09260-10003	BALL	1	1	1	
8	21121-93300	PLATE, clutch notch	-	1	-	
9	09440-07021	SPRING	1	1	1	
10-1	21211-93001	SHAFT, clutch lever	1	1	-	to 21211-93002
10-2	21211-93002	SHAFT, clutch lever	-	1	1	
11	22511-99000	GREASE NIPPLE	1	1	1	
12	21312-93300	ROD, inter lock	1	-	1	}
13	09160-06017	WASHER (5.5x13x2.3)	1	-	-	
14-1	21313-93300	PLATE, inter lock	1	-	-	}
14-2	21313-93400	PLATE, inter lock	-	-	1	
15	09164-09002	WAVE WASHER (9x20x2.3)	1	-	1	}
16	09111-06022	BOLT (6x20)	1	-	1	
17	21312-93300	ROD, inter lock	-	-	1	}
18	21313-93400	PLATE, inter lock	-	-	1	
19	09164-09002	WAVE WASHER (9x20x2.3)	-	-	1	}
20	09111-06022	BOLT (6x20)	-	-	1	
21	37310-93300	SWITCH ASSY, neutral inter lock	-	1	-	}
22	01107-06168	BOLT	-	1	-	
23	08322-21068	WASHER	-	1	-	}
24	08321-21068	LOCK WASHER	-	1	-	
25	09125-05028	SCREW	-	1	-	}
26	09404-06401	CLAMP	-	1	-	



FIG.36

H - 3

FIG.36 CLUTCH LEVER

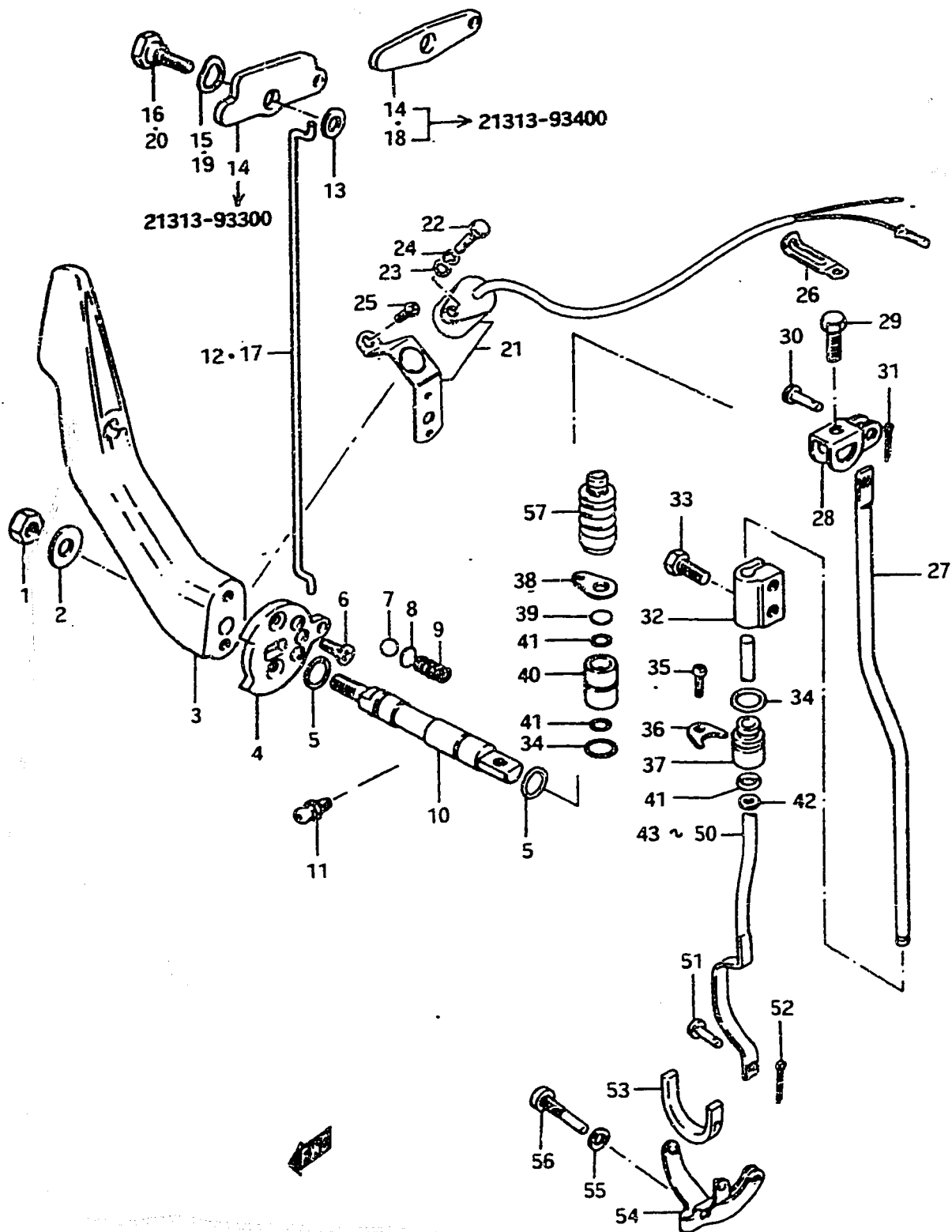

Ref. No.	Part No.	Description	Q'ty			Remarks
			C	D	F	
27	23111-93000	ROD, clutch	1	1	1	
28	23211-93000	ARM, clutch	1	1	1	
29	09100-06019	BOLT (6x16)	1	1	1	
30	09200-05006	PIN	1	1	1	
31	09204-01001	COTTER PIN	1	1	1	
32	23311-93001	CONNECTOR, clutch rod	1	1	1	
33	09100-06019	BOLT (6x16)	2	2	2	
34	09280-11001	O RING, rod guide	1	1	1	d:2.4, ID:10.8
35-1	02112-05128	SCREW	1	-	-	to 09125-05028
35-2	09125-05028	SCREW (5x12)	-	1	1	
36	25215-93000	STOPPER, rod guide	1	1	-	
37	25211-93002	GUIDE, shifting rod	1	1	-	
38-1	25215-93001	STOPPER, rod guide	-	-	1	DT20, DT25
38-2	25215-93002	STOPPER, rod guide	-	-	1	
38-3	25215-93401	STOPPER, rod guide	-	-	1	DT25E3, DT28
39	09160-06055	WASHER (7x12x1)	-	-	1	DT20, DT25
40-1	25211-93003	GUIDE, shifting rod L:16	-	-	1	
40-2	25211-93400	GUIDE, shifting rod L:18.5 to (25211-93401)+(25223-93400)	-	-	1	DT25E3, DT28
41	09280-06004	O RING (d:3.5, ID:5.8)	1	1	2	
42	08212-06151	WASHER	1	1	1	
43	25111-93700	ROD, shifting (L:418) S type	1	1	1	DT20, DT25
44	25111-93410	ROD, shifting (L:455)	-	-	1	DT25E3, DT28
45	25111-93000	ROD, shifting (L:537) L type	1	1	1	DT20, DT25
46	25111-93400	ROD, shifting (L:564)	-	-	1	DT25E3, DT28
47	25111-93710	ROD, shifting (L:588) LL type	1	1	1	DT20, DT25
48	25111-93420	ROD, shifting (L:615)	-	-	1	DT25E3, DT28
49	25111-93720	ROD, shifting (L:657) UL type	1	1	1	DT20, DT25
50	25111-93430	ROD, shifting (L:684)	-	-	1	DT25E3, DT28
51	09200-05006	PIN	1	1	1	
52	09204-01001	COTTER PIN	1	1	1	
53	25311-93000	CRADLE, clutch dog	1	1	1	
54	25120-93000	YOKE, shifting	1	1	1	
55	09168-06002	GASKET (6x11.8x1.5)	1	1	1	
56	09139-06005	SCREW, shifting yoke pilot	1	1	1	6x31
57	25222-93000	BOOTS, shifting rod	-	-	1	

FIG. 37

H - 4

FIG. 37 STARTING MOTOR

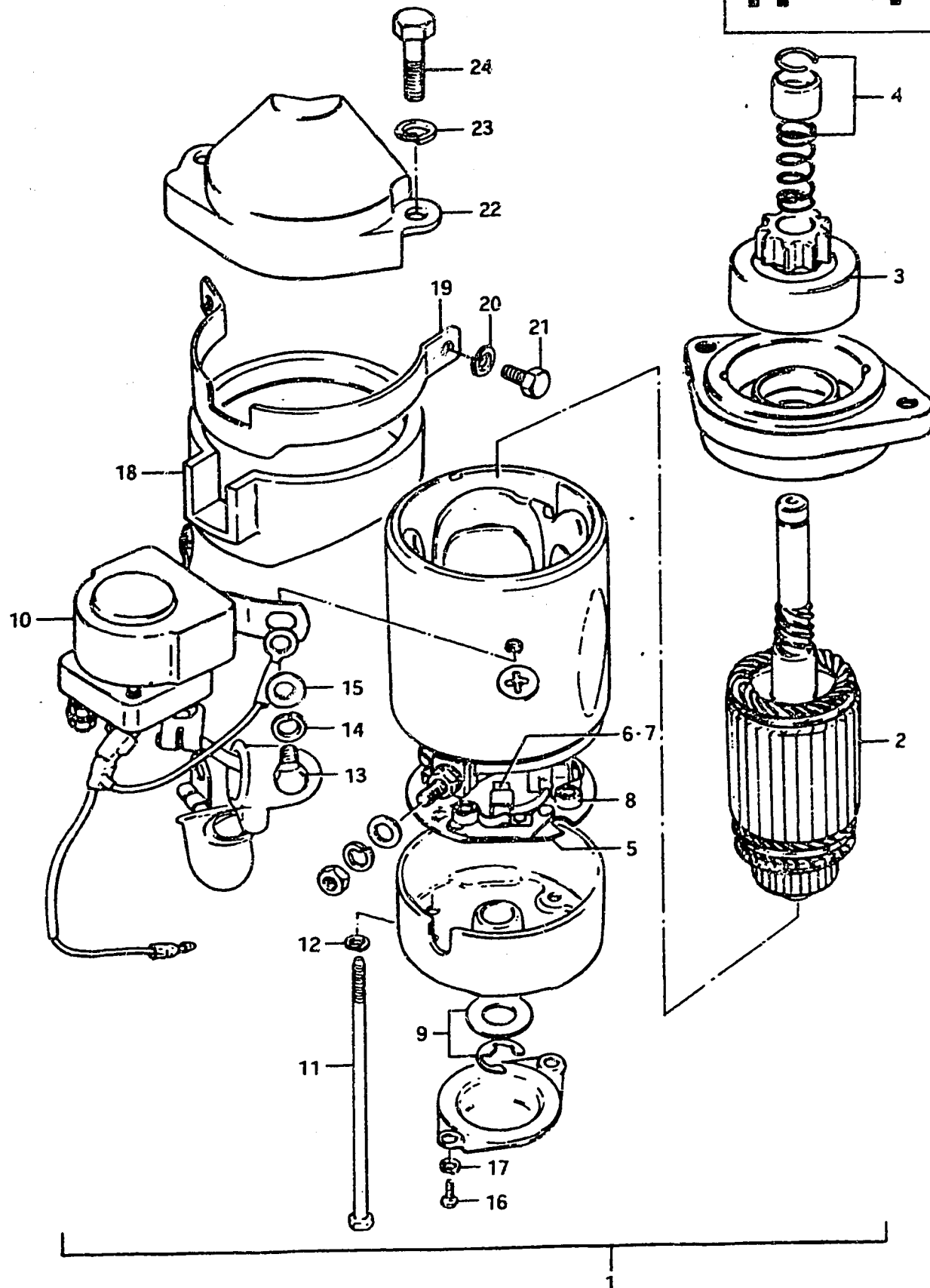

Ref. No.	Part No.	Description	Q'ty			Remarks
			C	D	F	
1-1	31100-95240	MOTOR ASSY, starting to 31100-95241	1	1	-	for Electric Starter
1-2	31100-93340	MOTOR ASSY, starting to 31100-93341	-	-	1	
2-1	31311-95240	•ARMATURE	1	1	-	
2-2	31310-93340	•ARMATURE	-	-	1	
3	31320-95240	•PINION ASSY	1	1	1	
4-1	31312-95240	•STOPPER SET, pinion	1	1	-	to 31312-95241
4-2	31312-95520	•STOPPER SET, pinion	-	-	1	
5-1	31173-95240	•HOLDER ASSY, motor brush	1	1	-	to 31173-95241
5-2	31173-93340	•HOLDER ASSY, motor brush	-	-	1	
6-1	31131-95241	••BRUSH (+)	2	2	-	from 31131-95240
6-2	31131-93340	••BRUSH (+)	-	-	1	
7-1	31132-95241	••BRUSH (-)	2	2	-	from 31132-95240
7-2	31132-93340	••BRUSH (-)	-	-	1	
8-1	31135-95240	••SPRING, motor brush	4	4	-	
8-2	31135-93340	••SPRING, motor brush	-	-	2	
9-1	31361-95240	•THRUST WASHER KIT	1	1	-	
9-2	31360-93340	•THRUST WASHER KIT	-	-	1	
10	31800-95241	•RELAY ASSY	1	1	1	from 31800-95240
11-1	31281-95240	•BOLT	2	2	-	
11-2	31281-93340	•BOLT	-	-	2	
12	08321-21058	•LOCK WASHER	2	2	2	
13-1	01107-06108	•BOLT (6x10)	2	2	-	
13-2	09100-06011	•BOLT (6x8)	-	-	2	
14	08321-21068	•LOCK WASHER	2	2	2	
15	08322-21068	•WASHER	2	2	2	
16	02112-04128	•SCREW	2	2	2	
17	08321-21048	•LOCK WASHER	2	2	2	
18	31915-93300	SPACER, starting motor	-	-	1	
19-1	31912-93300	BAND, starting motor	1	1	-	
19-2	31912-93301	BAND, starting motor	-	-	1	
20	08321-21068	LOCK WASHER	2	2	2	
21	01107-06168	BOLT	2	2	2	
22	31914-93300	COVER, starting motor	1	1	1	
23	08321-21088	LOCK WASHER	2	2	2	
24	01107-08408	BOLT	2	2	2	

FIG. 38

H - 5

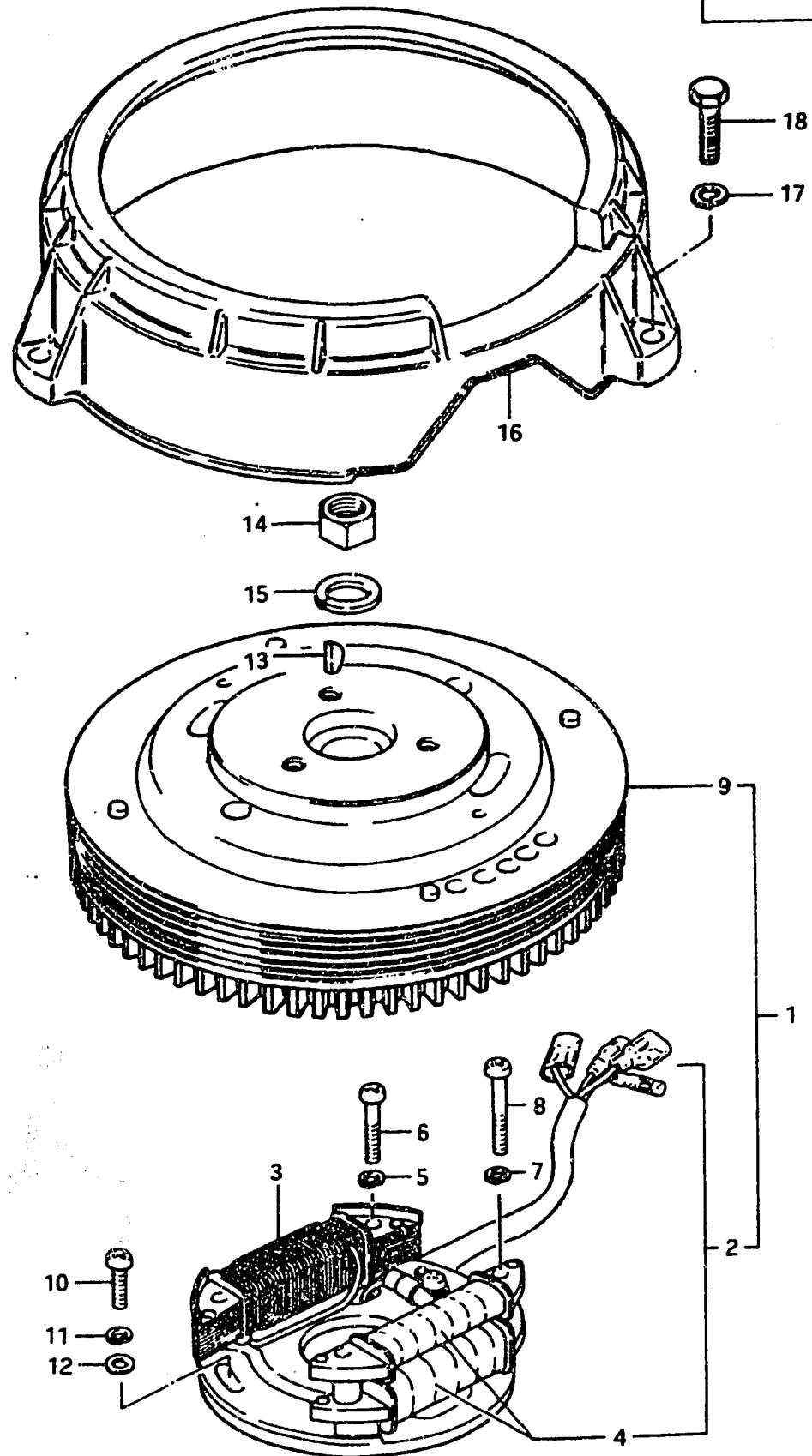

FIG. 38 MAGNETO 1

Ref. No.	Part No.	Description	Q'ty			Remarks
			C	D	F	
1-1	32100-93310	MAGNETO ASSY ~DT20C-11412,~DT25C-12300	1	-	-	to 32100-93311
1-2	32100-93311	MAGNETO ASSY	1	-	-	
1-3	32100-93312	MAGNETO ASSY	-	1	-	to 32100-93313
1-4	32100-93313	MAGNETO ASSY	-	-	1	to 32100-93314
2-1	32101-93310	•STATOR ASSY	1	-	-	to 32101-93311
2-2	32101-93312	•STATOR ASSY	-	1	1	from 32101-93311
3	32120-93311	••COIL ASSY, lighting (COIL, battery charging)	1	1	1	12V, 80W from 32120-93310
4-1	32160-93310	••COIL ASSY, ignition	1	1	-	to 32160-93311
4-2	32160-93311	••COIL ASSY, ignition	-	1	1	to 32160-93312
5	08321-21058	••LOCK WASHER	2	2	2	
6	02112-05258	••SCREW	2	2	2	
7	08321-21058	••LOCK WASHER	2	2	2	
8	02112-05358	••SCREW	2	2	2	
9-1	32102-93310	•ROTOR ASSY ~DT20C-11412,~DT25C-12300	1	-	-	to 32102-93311
9-2	32102-93311	•ROTOR ASSY	1	1	-	to 32102-93312
9-3	32102-93312	•ROTOR ASSY	-	-	1	
10	02112-05168	SCREW	2	2	2	
11	08321-21058	LOCK WASHER	2	2	2	
12	08322-11058	WASHER	2	2	2	
13	08341-31049	KEY	1	1	1	
14	08310-12148	NUT	1	1	1	
15	08321-21148	LOCK WASHER	1	1	1	
16	14312-93400-01J	COVER, magneto	-	-	1	} for Electric Starter
17	08321-21068	LOCK WASHER	-	-	3	
18	01107-06258	BOLT	-	-	3	

FIG. 39 (H-6) : DT20 (D, F) E13,  
DT25 F E13

FIG. 39

H - 6

FIG. 39 MAGNETO 2 (DT20 (D,F) E13, DT25 (F) E13)

Q'ty

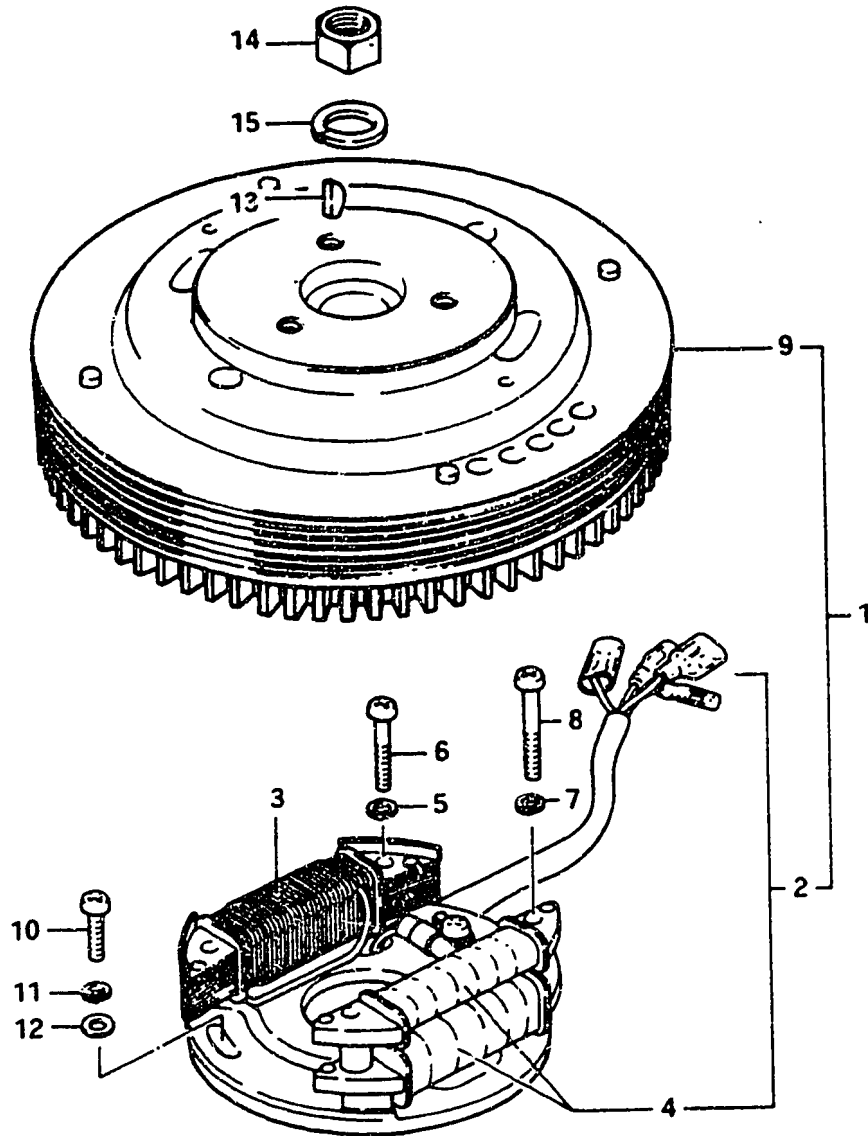

Ref. No.	Part No.	Description	D	F	Remarks
1-1	32100-93300	MAGNETO ASSY	1	-	to 32100-93301
1-2	32100-93301	MAGNETO ASSY	-	1	to 32100-93302
2	32101-93312	•STATOR ASSY	1	1	from 32101-93311
3	32120-93311	••COIL ASSY, lighting (COIL, battery charging)	1	1	12V, 80W from 32120-93310
4-1	32160-93310	••COIL ASSY, ignition	1	-	to 32160-93311
4-2	32160-93311	••COIL ASSY, ignition	1	1	to 32160-93312
5	08321-21058	••LOCK WASHER	2	2	
6	02112-05258	••SCREW	2	2	
7	08321-21058	••LOCK WASHER	2	2	
8	02112-05358	••SCREW	2	2	
9-1	32102-93300	•ROTOR ASSY	1	-	to 32102-93301
9-2	32102-93301	•ROTOR ASSY	-	1	
10	02112-05168	SCREW	2	2	
11	08321-21058	LOCK WASHER	2	2	
12	08322-11058	WASHER	2	2	
13	08341-31049	KEY	1	1	
14	08310-12148	NUT	1	1	
15	08321-21148	LOCK WASHER	1	1	

FIG.40

H - 7

FIG.40 IGNITION

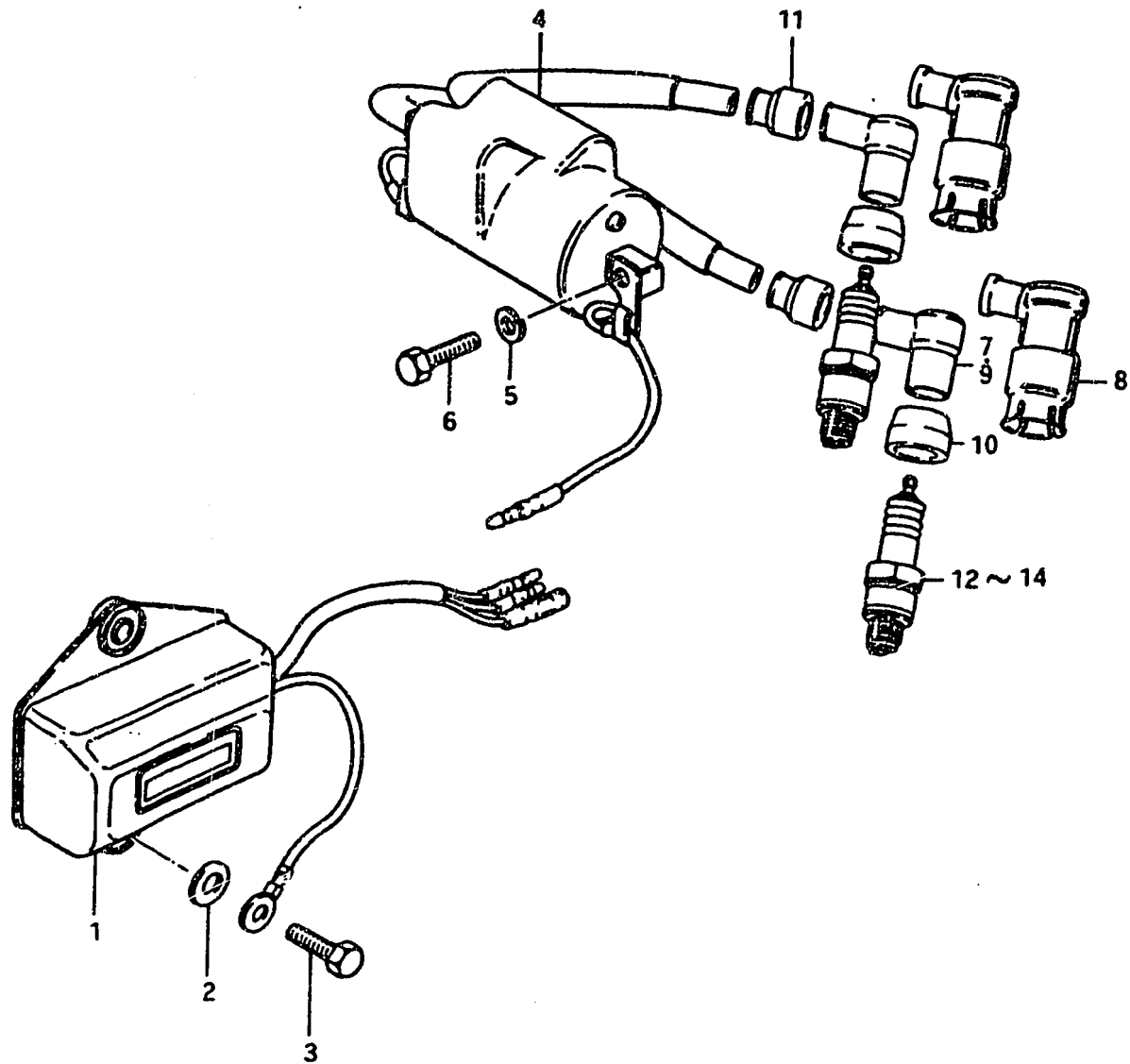

Ref. No.	Part No.	Description	Qty			Remarks
			C	D	F	
1-1	32900-95210	C.D.UNIT, ignition	1	-	-	ND
1-2	32900-93310	C.D.UNIT, ignition	-	1	1	
1-3	32900-93300	C.D.UNIT, ignition	-	1	1	
2-1	09160-06019	WASHER (6.5x16x1.2)	2	2	-	
2-2	09160-06052	WASHER (6.5x16x1.2)	-	-	2	
3	01107-06208	BOLT	2	2	2	
4	33410-93310	COIL ASSY, ignition	1	1	1	
5	08321-21068	LOCK WASHER	2	2	2	
6	01107-06208	BOLT	2	2	2	
7	33510-28300	CAP, spark plug	2	-	-	
8-1	33510-93310	CAP, spark plug	2	-	-	DT20C E28 to (33510-22010)+ (33541-93310)
8-2	33510-93310	CAP, spark plug	-	2	2	
9	33510-41111	CAP, spark plug to 33510-95510	-	2	2	DT20(D,F)E13, DT25FE13
10-1	33541-98002	SEAL, spark plug	2	-	-	
10-2	33541-93310	SEAL, spark plug	-	-	2	for 33510-22010
11	33542-98000	SEAL, high tension cord	2	2	2	
12	09482-00082	SPARK PLUG (NGK,B7HS)	2	-	-	
13-1	09482-00116	SPARK PLUG (NGK,BR7HS)	2	-	-	DT20CE28
13-2	09482-00116	SPARK PLUG (NGK,BR7HS)	-	2	2	
14	09482-00198	SPARK PLUG (NGK,B8HS)	-	-	2	DT25FE13

FIG. 41

H - 8

FIG. 41 ELECTRICAL 1

Q'ty

Ref. No.	Part No.	Description	C	D	F	Remarks
1	32800-95720	RECTIFIRE ASSY	1	1	1	
2	02112-05258	SCREW	1	1	1	
3	32890-93300	HOLDER, electric parts	1	1	1	
4	08321-21058	LOCK WASHER	1	1	1	
5	08310-11058	NUT	1	1	1	
6-1	09160-06019	WASHER (6.5x16x1.2)	4	4	-	
6-2	09160-06052	WASHER	-	-	2	
7	09180-06035	SPACER (6.1x8x12)	2	2	2	
8	09320-08015	CUSHION	2	2	2	
9	01107-06258	BOLT	2	2	2	
10-1	33810-93300	CABLE ASSY, starting motor	1	-	-	L:1870(-),L:1680(+) to 33810-93301
10-2	33810-93301	CABLE ASSY, starting motor	-	1	-	to 33810-93350 for Electric Starter
10-3	33810-93351	CABLE ASSY, starting motor	-	-	1	from 33810-93350
11	36659-93300	CLAMP, starter cable	1	1	1	
12	02142-04127	SCREW	1	1	1	
13	36656-93300	GROMMET, cable	1	1	1	
14-1	36740-95250	CASE ASSY, fuse	1	1	-	to 36740-95251
14-2	36740-95252	CASE ASSY, fuse	-	1	1	from 36740-95251
15	09481-20001	FUSE (20A)	1	1	1	
16	36791-95200	HOLDER, fuse	-	1	1	
17	09125-06020	SCREW (L:16)	1	1	1	
18-1	36610-93350	WIRING HARNESS (1)(L:430)	1	-	-	
18-2	36610-93310	WIRING HARNESS (1)(L:500)	-	1	-	
19	36610-93300	WIRING HARNESS (1)	-	1	-	E3
20-1	09404-06414	CLAMP (L:80)	2	-	-	
20-2	09404-06412	CLAMP (L:60)	-	2	2	
21	36651-93300	PACKING, joint box	1	1	1	
22	36650-93300	COVER, joint box	1	1	1	
23-1	36652-93301	LABEL, joint diagram	1	-	-	
23-2	36652-93302	LABEL, joint diagram	-	1	1	
24	09125-05025	SCREW (5x12)	4	4	4	
25	36654-93300	GROMMET, joint box	2	2	2	
26	36658-93300	COVER, wiring harness	1	1	1	

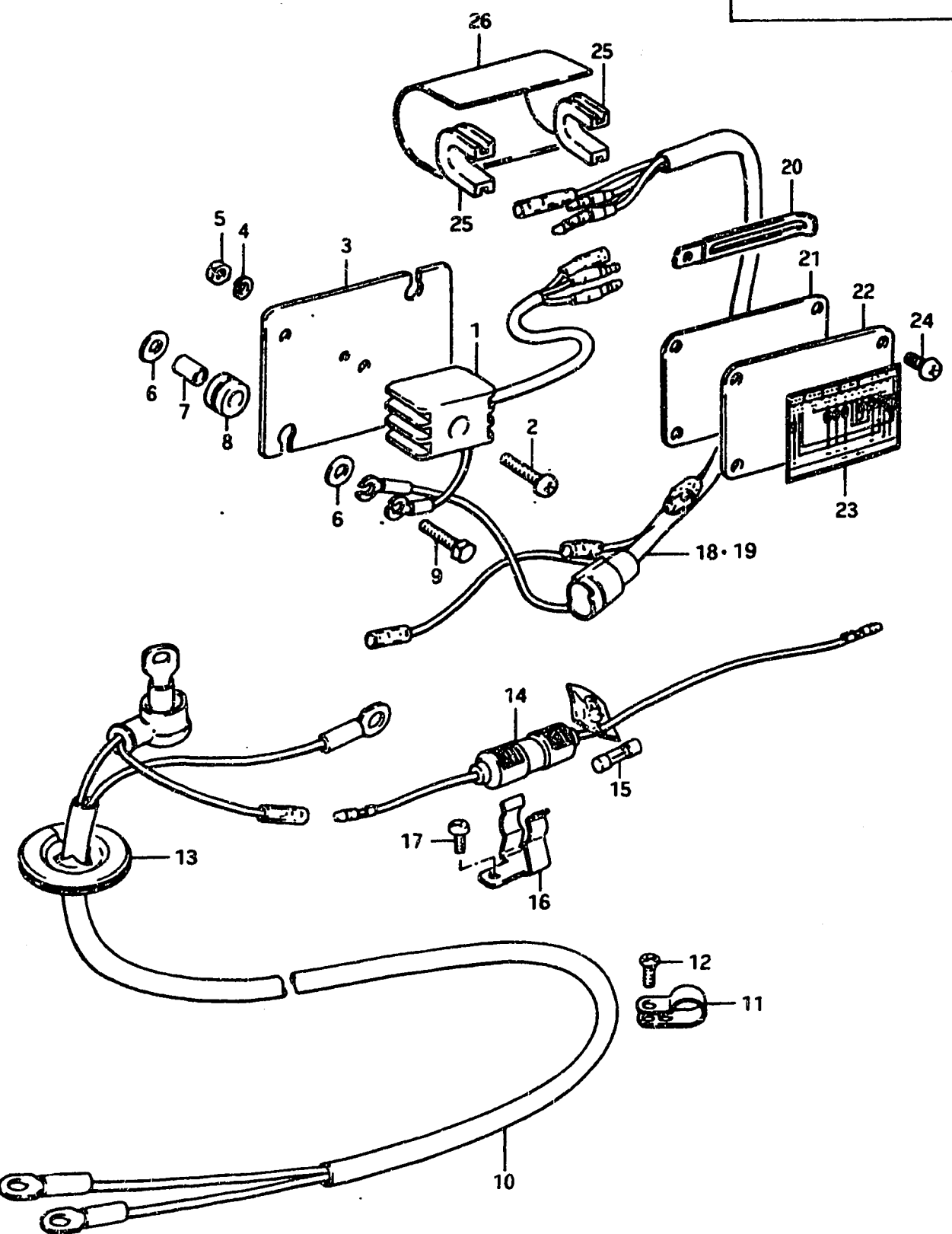

FIG.42

H - 9

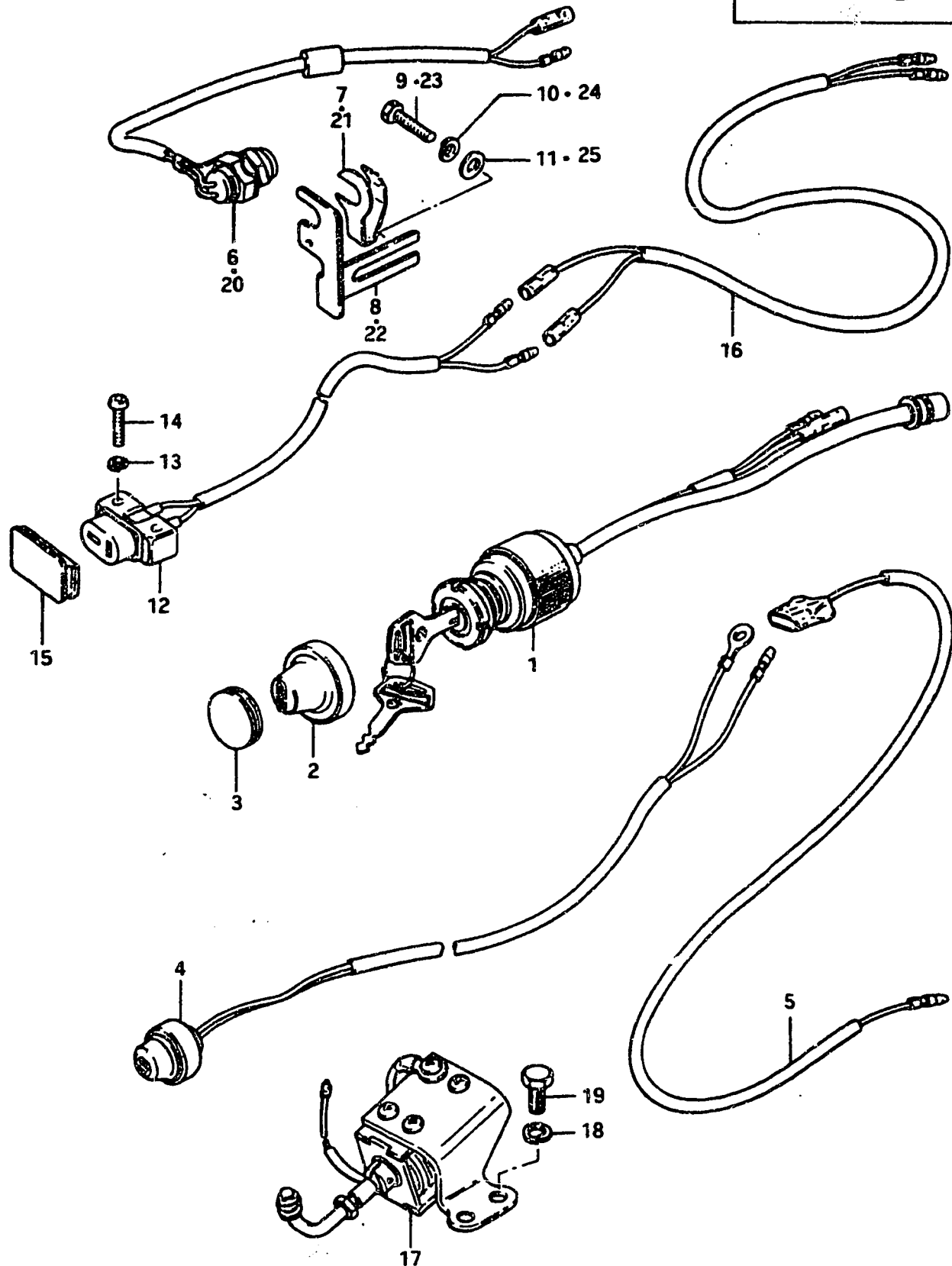

FIG.42 ELECTRICAL 2

Ref. No.	Part No.	Description	Q'ty			Remarks
			C	D	F	
1-1	37110-93350	SWITCH ASSY, ignition (L:220)	1	-	-	
1-2	37110-93351	SWITCH ASSY, ignition (L:120)	-	1	-	for Electric Starter
1-3	37110-93301	SWITCH ASSY, ignition (L:600)	-	-	1	from 37110-93300, to 37110-93302
2	37921-97001	COVER, ignition switch	1	1	-	
3	09250-20004	CAP	1	1	1	for Hand Starter
4-1	37800-99015	SWITCH ASSY, stop	1	1	1	to 37800-99016
4-2	37800-93350	SWITCH ASSY, stop	-	-	1	from 37800-99016
5	36895-93300	LEAD WIRE, stop switch	1	1	1	for Hand Starter
6	37721-95250	SWITCH, neutral	1	-	1	
7	37725-95201	ACTUATER, neutral switch	1	-	1	
8-1	37726-93301	BRACKET, neutral switch	1	-	-	to 37726-93302
8-2	37726-93302	BRACKET, neutral switch	-	-	1	for Electric Starter
9	09100-06020	BOLT (6x20)	1	-	2	
10	09162-06001	LOCK WASHER	1	-	2	
11	09160-06015	WASHER (6.5x13x1)	1	-	2	
12	39601-96711	CONSENT ASSY, lamp	1	-	-	
13	08322-21048	WASHER	2	-	-	for Hand Starter
14	02112-04208	SCREW	2	-	-	
15	39669-93500	CAP, consent from 39669-93300	*1	1	1	*for Electric Starter (model C)
16	36896-93300	LEAD WIRE, consent	1	-	-	for Hand Starter
17	38600-93750	SOLENOID ASSY, choke	-	-	1	to 38600-93810
18	09162-05002	LOCK WASHER	-	-	2	OPT
19	09100-05102	BOLT (5x10)	-	-	2	
20	37721-95251	SWITCH ASSY, neutral	-	-	1	
21	37725-95201	ACTUATER, neutral switch	-	-	1	
22	37726-93302	BRACKET, neutral switch	-	-	1	DT25E3
23	09100-06020	BOLT (6x20)	-	-	2	(for Hand Starter)
24	09162-06001	LOCK WASHER	-	-	2	
25	09160-06015	WASHER (6.5x13x1)	-	-	2	

FIG.43

H - 10

FIG.43 CLAMP BRACKET

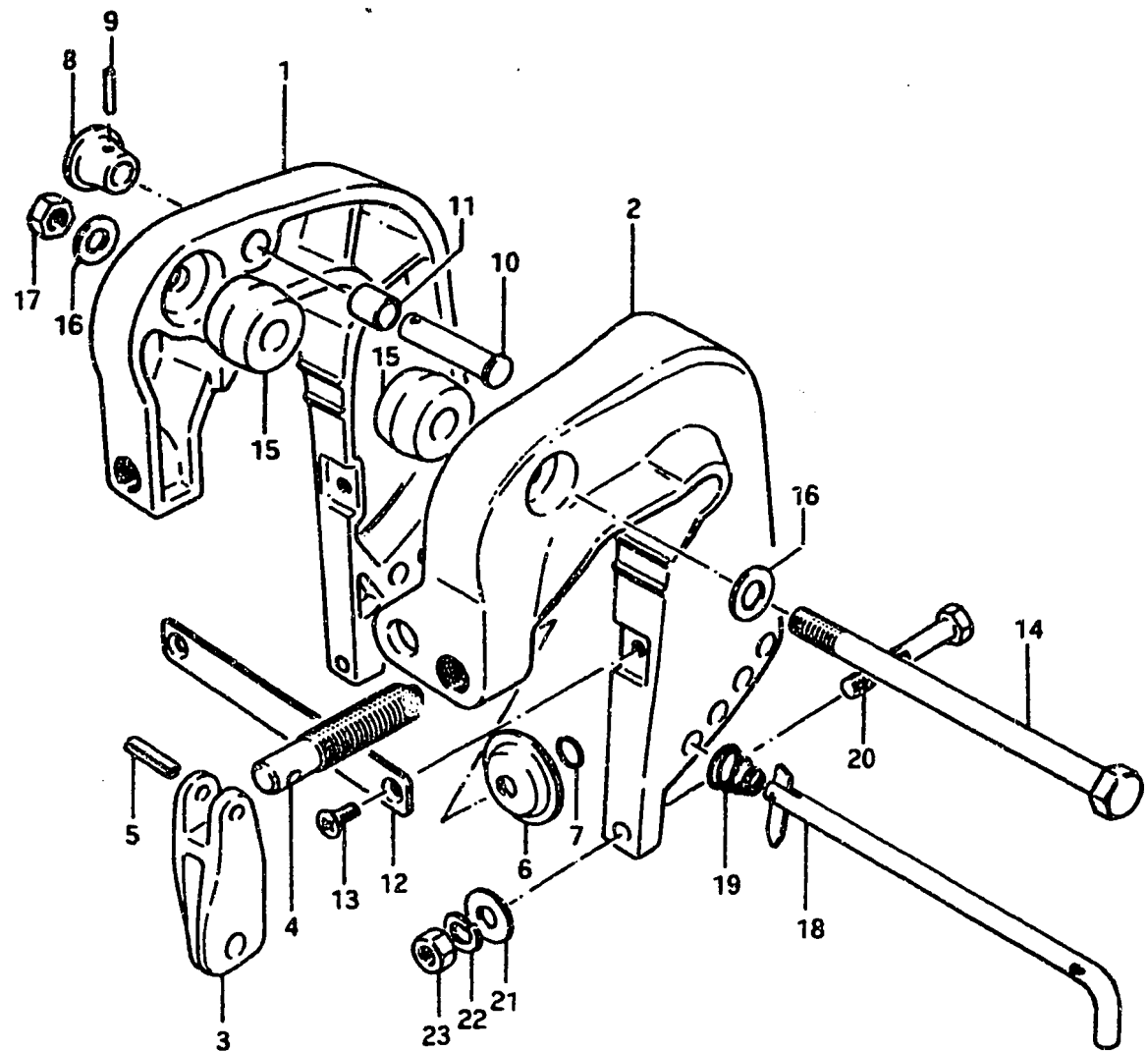

Ref. No.	Part No.	Description	Q'ty			Remarks
			C	D	F	
1-1	41111-93003-01J	BRACKET, clamp RH	1	1	-	to 41111-93004-01J
1-2	41111-93004-01J	BRACKET, clamp RH	-	-	1	
2-1	41121-93002-01J	BRACKET, clamp LH	1	1	-	to 41121-93003-01J
2-2	41121-93003-01J	BRACKET, clamp LH	-	-	1	to 41121-93004-01J
2-3	41121-93004-01J	BRACKET, clamp LH	-	-	1	
3	41212-93000-01J	HANDLE, clamp	2	2	2	
4-1	41211-93000	SCREW, clamp (L:78)	2	2	2	
4-2	41211-93700	SCREW, clamp (L:90)	2	2	2	OPT
4-3	41211-93710	SCREW, clamp (L:68)	2	2	2	
5	09205-06007	PIN, clamp handle	2	2	2	
6	41213-93000	PLATE, clamp	2	2	2	
7	09380-07001	RING, clamp plate	2	2	2	
8	41221-93001	KNOB, tilt stopper	1	1	1	
9	09205-03015	PIN, tilt stopper knob (L:18)	1	1	1	
10	09200-12001	PIN, tilt stopper (OD:12)	1	1	1	
11	09300-12009	BUSHING (12x15x20)	1	1	1	
12	41311-93000	PLATE, clamp bracket	1	1	1	
13	09126-06001	SCREW (6x12)	2	2	2	
14	09100-10086	BOLT (10x175)	1	1	1	
15	09306-11002	BUSHING, swivel bracket	2	2	2	
16	09160-10040	WASHER, swivel bracket	2	2	2	10.5x18x1.6
17	09140-10015	NUT, swivel bracket	1	1	1	
18	45420-93000	PIN, tilt lock	1	1	1	
19	09441-17001	SPRING, tilt lock pin	1	1	1	
20	09100-08111	BOLT, transom (8x90)	2	-	-	
21	09160-08014	WASHER, transom (2)	2	-	-	8.5x23x1.5
22	09162-08003	LOCK WASHER, transom	2	-	-	
23	09140-08003	NUT, transom	2	-	-	

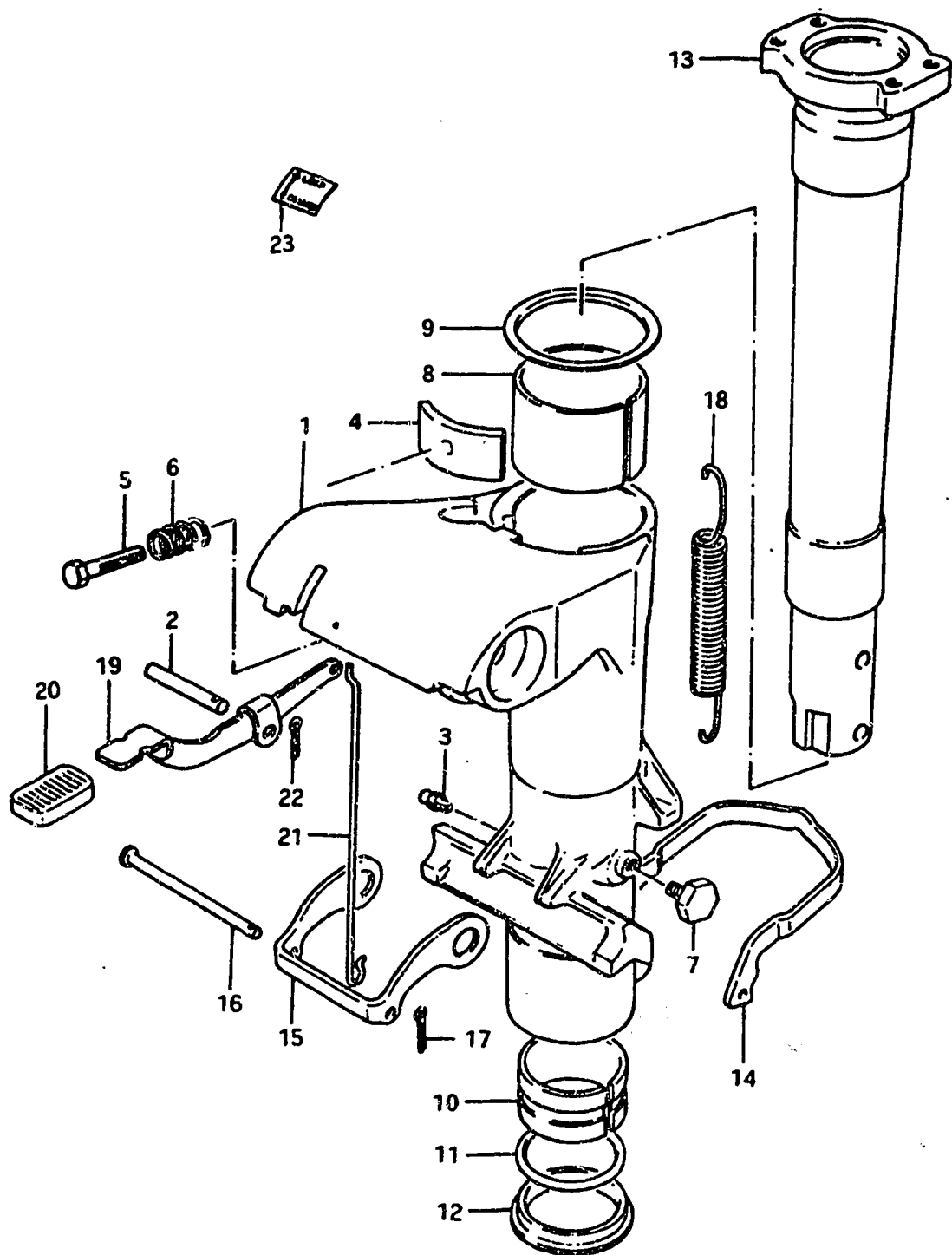

FIG. 44

H - 11

23

FIG. 44 SWIVEL BRACKET



Ref. No.	Part No.	Description	Q'ty			Remarks
			C	D	F	
1-1	43111-93300-01J	BRACKET, swivel	1	1	-	to 43111-93301-01J
1-2	43111-93301-01J	BRACKET, swivel to (43111-93302-01J)+(09100-08112)+(09440-13013)	-	1	-	
1-3	43111-93302-01J	BRACKET, swivel	-	-	1	
1-4	43111-93303-01J	BRACKET, swivel to (43111-93990-01J)+(22511-99000)	-	-	1	from 43111-93302-01J
2	09200-05005	PIN, swivel bracket	1	1	1	
3	22511-99000	GREASE NIPPLE, swivel bracket	1	1	1	
4	43410-93000	ADJUSTER, steering	1	1	1	
5-1	09100-06049	BOLT, adjusting (6x30)	1	1	-	
5-2	09100-08112	BOLT, adjusting (8x30)	-	-	1	
6-1	09440-12008	SPRING, adjusting	1	1	-	
6-2	09440-13013	SPRING, adjusting	-	-	1	
7	09100-06071	BOLT (6x7)	2	2	-	
8	43711-93000	BUSHING, steering upper	1	1	1	
9	43712-93000	PLATE, upper bushing	1	1	1	
10	43721-93000	BUSHING, steering lower	1	1	1	
11	09280-40004	O RING, swivel bracket	1	1	1	d:3.5, ID:40
12	09306-40001	BUSHING, steering O ring	1	1	1	
13-1	43741-93001-01J	SHAFT, pilot	1	1	-	to 43741-93002-01J
13-2	43741-93002-01J	SHAFT, pilot	-	1	1	
14-1	45231-93001	ARM, reverse lock	1	1	-	to 45231-93002
14-2	45231-93002	ARM, reverse lock	-	-	1	
15	45241-93000	LINK, reverse lock arm	1	1	1	
16	09200-04003	PIN, reverse lock arm	1	1	1	
17	09204-01001	COTTER PIN	1	1	1	
18	09443-14010	SPRING, reverse lock	1	1	1	
19	45251-93000	LEVER, release	1	1	1	to 45251-93001
20	45255-93000	RUBBER, release lever	1	1	1	
21	45252-93000	LINK, release lever	1	1	1	
22	09204-01001	COTTER PIN	1	1	1	
23-1	43241-93100	MARK, release lever	1	1	-	English only to 43241-93101
23-2	43241-93101	MARK, release lever	-	1	1	English+French

FIG. 45

H - 12

FIG. 45 STEERING BRACKET

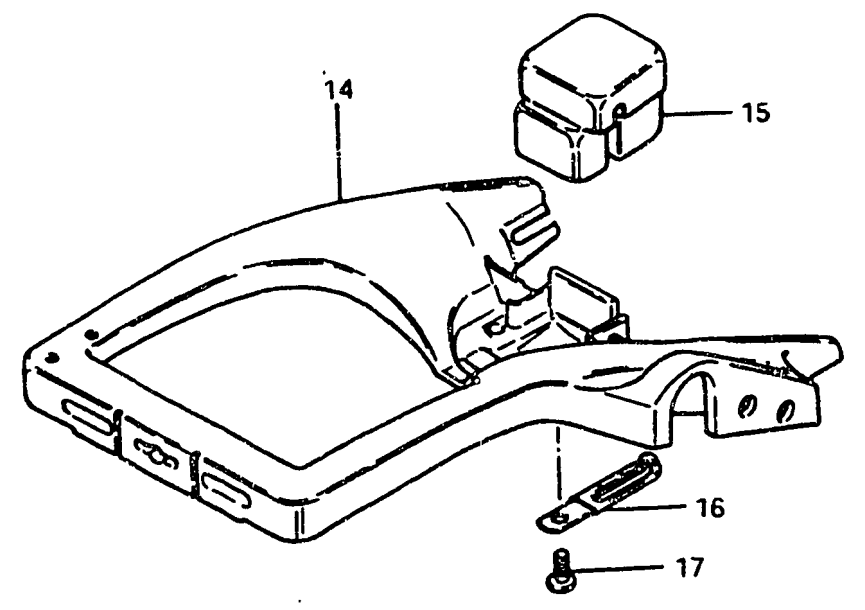
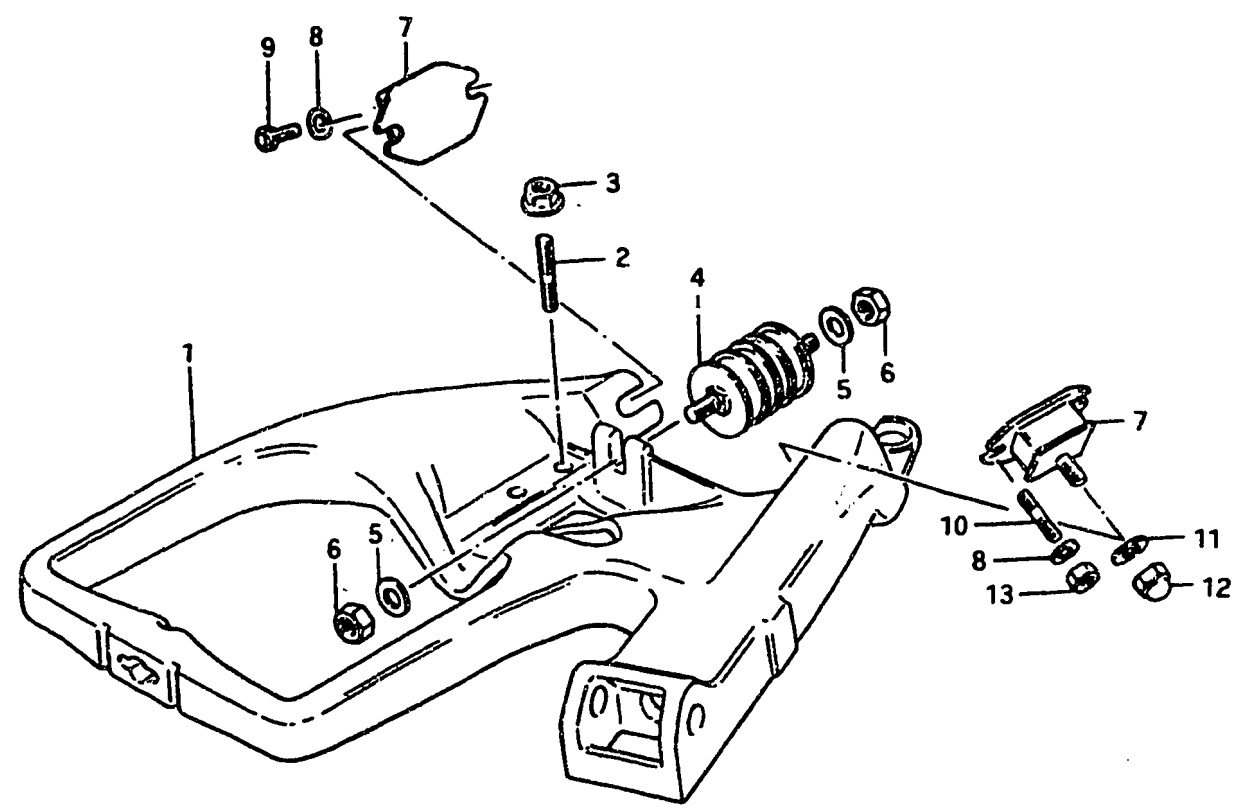

Ref. No.	Part No.	Description	Q'ty			Remarks
			C	D	F	
1-1	43750-93300-01J	BRACKET, steering	1	1	-	to 43750-93301-01J
1-2	43750-93301-01J	BRACKET, steering	-	1	-	DT25D-10583~
2	09108-08039	STUD BOLT (8x25)	4	4	4	
3-1	09159-08019	NUT	4	4	-	to 08316-16088
3-2	08316-16088	NUT	-	-	4	
4-1	54120-93300	MOUNTING, thrust upper	1	1	-	S, L & LL type to 54120-93302
4-2	54120-93301	MOUNTING, thrust upper	-	1	-	UL type to 54120-93302
5	09160-08015	WASHER (8.5x16x1.2)	2	2	-	
6	09140-08003	NUT	2	2	-	
7-1	54130-93300	MOUNTING, upper (~DT20D-11093)	2	2	-	~DT25D-12543 to 54130-93301
7-2	54130-93301	MOUNTING, upper	-	2	-	to 54130-93402
7-3	54130-93402	MOUNTING, upper	-	-	2	
8	09160-06015	WASHER (1)	4	4	4	
9	09100-06019	BOLT (6x16)	1	1	1	
10	09108-06022	STUD BOLT	3	3	3	
11	09160-08015	WASHER (2) (8.5x16x1.2)	2	2	2	
12	09145-08002	CROWN NUT	2	2	2	
13	09140-06004	NUT, upper mounting	3	3	3	
14	43751-93410-01J	BRACKET, steering	-	-	1	
15	54120-93400	MOUNTING, thrust upper	-	-	1	
16	09404-06415	CLAMP (L:95)	-	-	1	
17	09125-05028	SCREW, clamp	-	-	1	

FIG. 46

H - 13

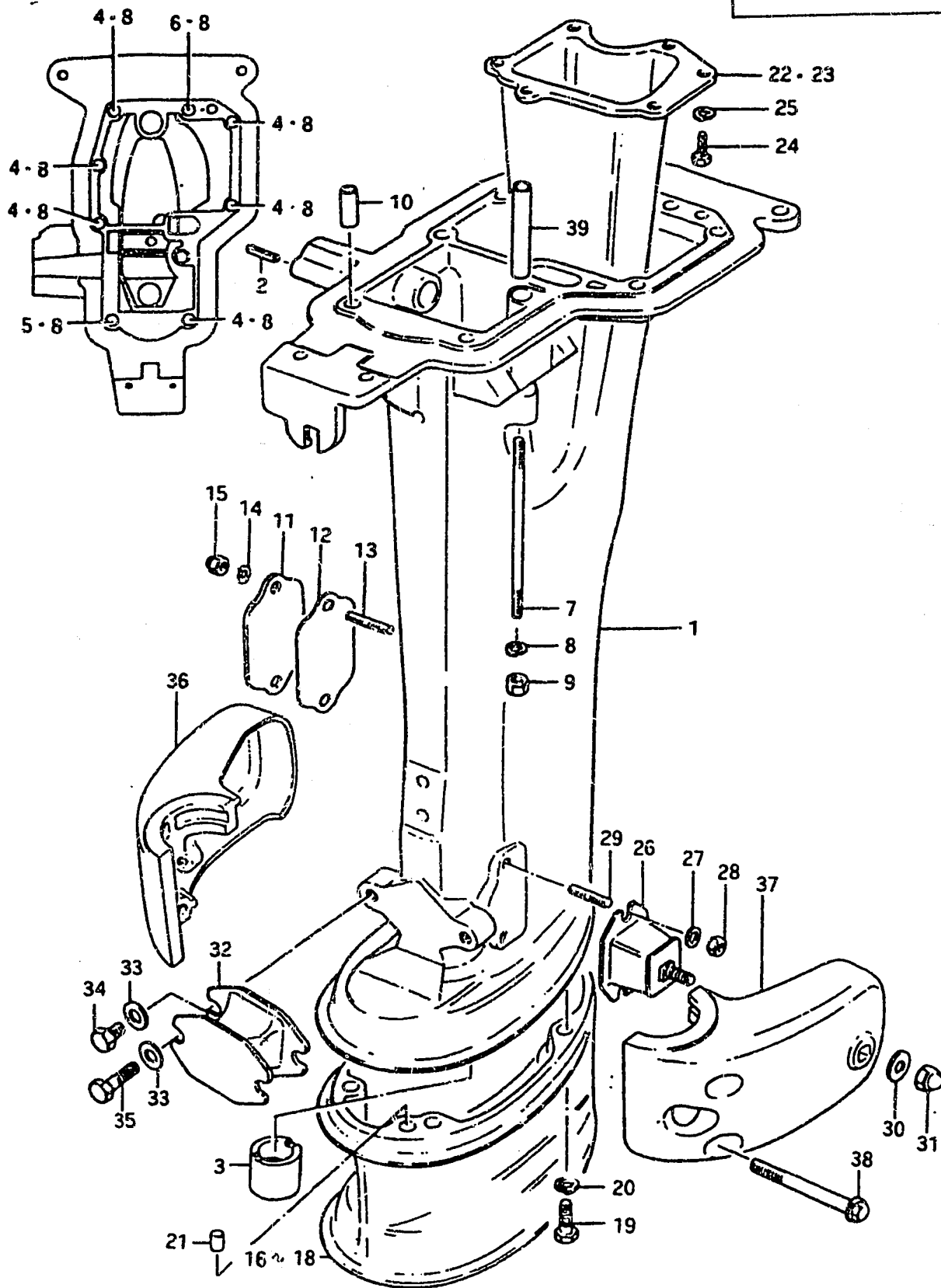

FIG. 46 DRIVESHAFT HOUSING

Ref. No.	Part No.	Description	Q'ty			Remarks
			C	D	F	
1-1	52100-93823-01J	HOUSING, driveshaft (Incl. Ref. No. 3)	1	-	-	See Note : to 52110-93300-01J
1-2	52110-93300-01J	HOUSING, driveshaft	1	1	-	
1-3	52110-93401-01J	HOUSING, driveshaft	-	-	1	
2	09205-05001	PIN, clutch lever	1	1	1	
3	09305-15002	BUSHING, driveshaft	1	1	1	LL, UL type 15.8x26x2.5
4	09100-06046	BOLT (1) (6x45)	6	6	6	
5	09100-06072	BOLT (2) (6x65)	1	1	1	
6-1	09100-06044	BOLT (3) (6x70)	1	-	-	
6-2	09100-06021	BOLT (3) (6x50)	1	1	1	
7	09108-06031	STUD BOLT, housing	1	1	1	
8	09162-06001	LOCK WASHER	9	9	9	
9	09140-06004	NUT	1	1	1	
10	09206-09003	DOWEL PIN	2	2	2	
11	52115-93000-01J	COVER, clutch adjusting hole	1	1	1	
12	52116-93000	GASKET, clutch adjusting hole	1	1	1	
13	09108-06022	STUD BOLT	2	2	2	
14	09162-06001	LOCK WASHER	2	2	2	
15	09145-06001	CROWN NUT	2	2	2	
16	52131-93001-01J	CASE, extension (L:119)	1	1	1	L type
17	52131-93710-01J	CASE, extension (L:170)	1	1	1	LL type
18	52131-93720-01J	CASE, extension (L:239)	1	1	1	UL type
19	09100-08112	BOLT, extension (8x30)	5	5	5	L, LL & UL type
20	09162-08003	LOCK WASHER	5	5	5	
21	09202-09002	DOWEL PIN	2	2	2	

Note : When you use the Driveshaft Housing (52100-93823-01J) to L type and S type, please be sure to take off a bushing (09305-15002).

FIG. 46

H - 14

FIG. 46 DRIVE SHAFT HOUSING

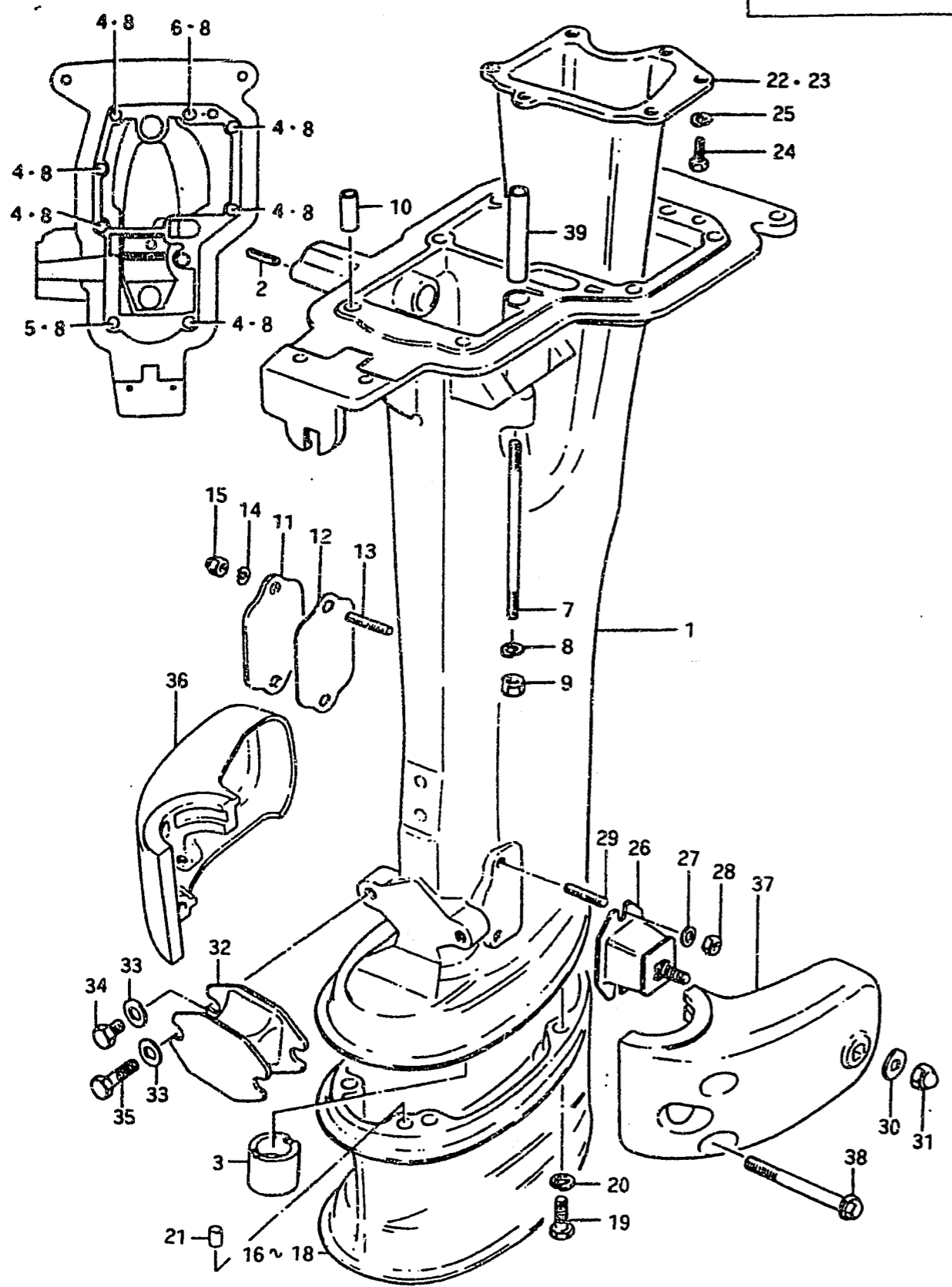

Ref. No.	Part No.	Description	Q'ty			Remarks
			C	D	F	
22-1	52141-93000	TUBE, exhaust (L:200)	1	1	-	L, LL & UL type
22-2	52141-93400	TUBE, exhaust (L:150)	-	-	1	
23-1	52141-93710	TUBE, exhaust (L:250)	1	1	-	from 52141-93700
23-2	52141-93410	TUBE, exhaust (L:250)	-	-	1	S type
24-1	09100-05102	BOLT, exhaust tube (5x10)	6	6	-	
24-2	09100-05004	BOLT, exhaust tube (5x12)	-	-	6	
25	09162-05002	LOCK WASHER	6	-	-	
26-1	54130-93300	MOUNTING, lower ~DT20D-11093,~DT25D-12543	2	2	-	to 54130-93301
26-2	54130-93301	MOUNTING, lower	-	2	-	to 54130-93402
26-3	54130-93402	MOUNTING, lower	-	-	2	
27	09160-06015	WASHER (1), (6.5x11.5x0.8)	4	4	4	
28	09140-06004	NUT	4	4	4	
29	09108-06022	STUD BOLT, lower mounting	4	4	4	6x12
30	09160-08015	WASHER (2), (8.5x16x1.2)	2	2	2	
31	09145-08002	CROWN NUT, lower mounting	2	2	2	
32-1	54150-93300	MOUNTING, thrust lower ~DT20D-11093,~DT25D-12543	1	1	-	to 54150-93301
32-2	54150-93301	MOUNTING, thrust lower	-	1	-	to 54150-93400
32-3	54150-93400	MOUNTING, thrust lower	-	-	1	
33	09160-08015	WASHER, thrust mounting	4	4	4	8.5x16x1.2
34-1	09100-08090	BOLT, thrust mounting (8x16)	2	2	-	
34-2	09100-08152	BOLT, thrust mounting (8x13)	-	-	2	
35	09100-08137	BOLT, thrust mounting (8x30)	2	2	2	
36-1	54211-93002-01J	COVER, mounting RH	1	1	-	to 54211-93003-01J
36-2	54211-93003-01J	COVER, mounting RH	-	-	1	
37-1	54221-93002-01J	COVER, mounting LH	1	1	-	to 54221-93003-01J
37-2	54221-93003-01J	COVER, mounting LH	-	-	1	
38	09103-08006	BOLT, mounting cover (8x60)	2	2	2	
39	09206-09004	PIN (6.3x9x64)	1	1	1	

FIG.47

FIG.47 GEAR CASE (DT20, DT25)

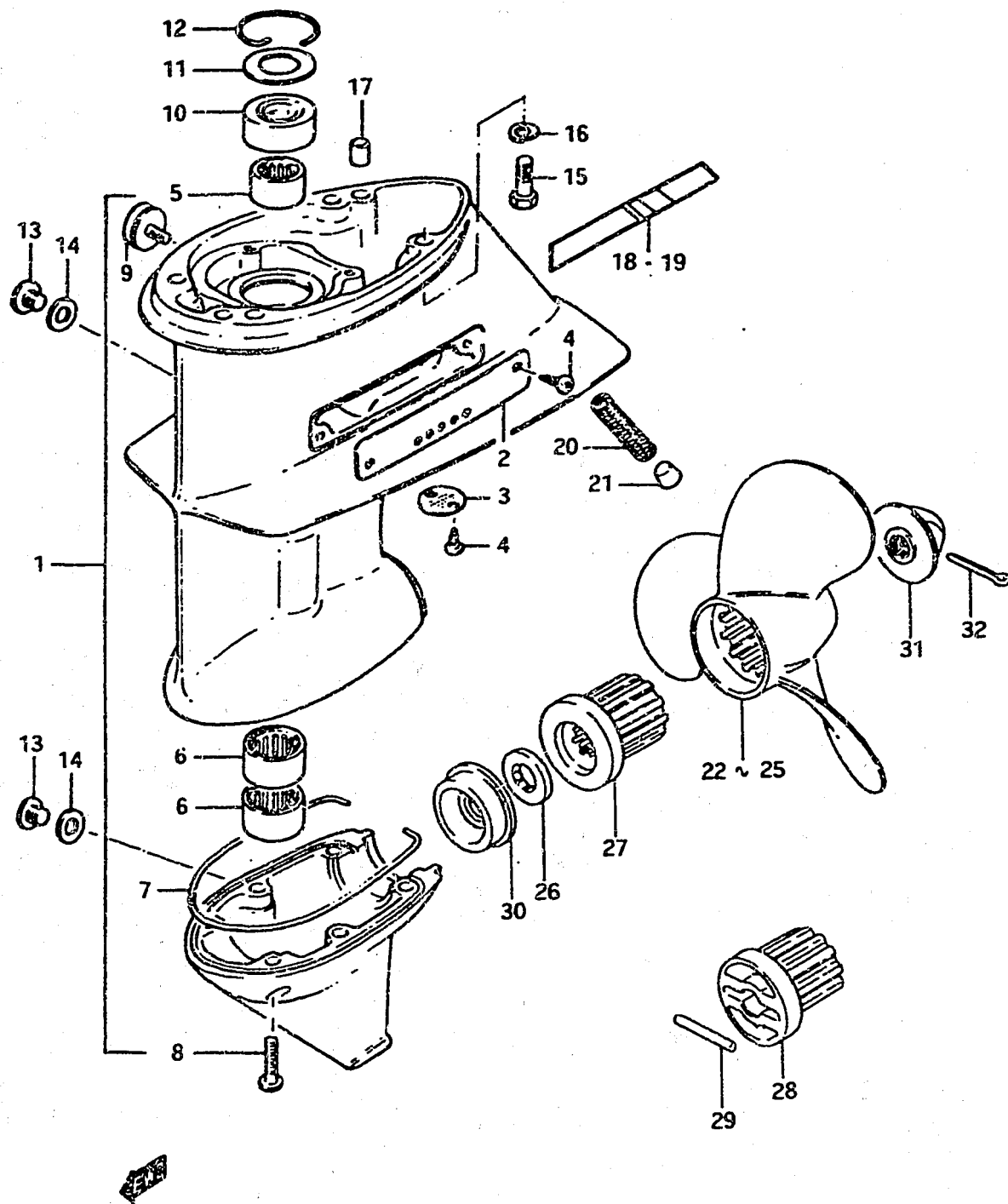

Ref. No.	Part No.	Description	Qty			Remarks
			C	D	F	
1-1	55100-93813-01J	CASE ASSY, gear	1	1	1	to 55100-93814-01J
1-2	55100-93814-01J	CASE ASSY, gear	-	-	1	
2	55112-93000	·COVER, gear case side	1	1	1	
3-1	55114-93000	·COVER, gear case lower	1	1	-	to 55114-98500
3-2	55114-98500	·COVER, gear case lower	-	1	1	
4-1	03212-04109	·SCREW	4	-	-	to 03112-04109
4-2	03112-04109	·SCREW	-	4	4	
5	09263-20013	·BEARING, driveshaft	1	1	1	20x28x16
6	09263-24010	·BEARING, pinion (24x32x20)	2	2	2	
7	09280-00005	·SEAL, strip	1	1	1	to 55122-93400
8	09103-06003	·BOLT, lower gear case (6x25)	6	6	6	
9	55321-93141	·ZINC, protection	1	1	1	from 55321-93140
10-1	09289-22002	OIL SEAL, gear case (36x22x10)	1	1	1	to 09289-22005
10-2	09289-22005	OIL SEAL, gear case (36x22x10)	-	-	1	
11	09161-23001	WASHER, gear case oil seal	1	1	1	23x36x1
12	09387-36001	SET RING, gear case oil seal	1	1	1	
13	09248-10003	PLUG, drain	2	2	2	
14	09168-10004	GASKET, drain plug (10x17x2)	2	2	2	to 09168-10022
15	09100-08112	BOLT, gear case (8x30)	4	4	4	
16	09162-08003	LOCK WASHER, gear case	4	4	4	
17	09202-09002	DOWEL PIN, gear case	2	2	2	
18	55141-93300	EMBLEM, gear case side, RH	1	1	1	
19	55151-93300	EMBLEM, gear case side, LH	1	1	1	
20	17631-93000	FILTER, water	1	1	1	
21	09243-11004	PLUG, water filter	1	1	1	
22-1	58111-93700-01T	PROPELLER	1	1	-	to 58111-93701-01T
22-2	58111-93701-01T	PROPELLER	-	1	1	K1200
23-1	58111-93710-01T	PROPELLER	1	1	-	to 58111-93711-01T
23-2	58111-93711-01T	PROPELLER	-	1	1	K1100
24-1	58111-93750-01T	PROPELLER	1	1	-	to 58111-93751-01T
24-2	58111-93751-01T	PROPELLER	-	1	1	K901
25-1	58111-93780-01T	PROPELLER	1	1	-	to 58111-93781-01T
25-2	58111-93782-01T	PROPELLER	-	1	1	STD, H1000 from 58111-93782-01T

FIG.48 (i-4) : DT25F E3, DT28F

FIG.47

FIG.47 GEAR CASE (DT20, DT25)

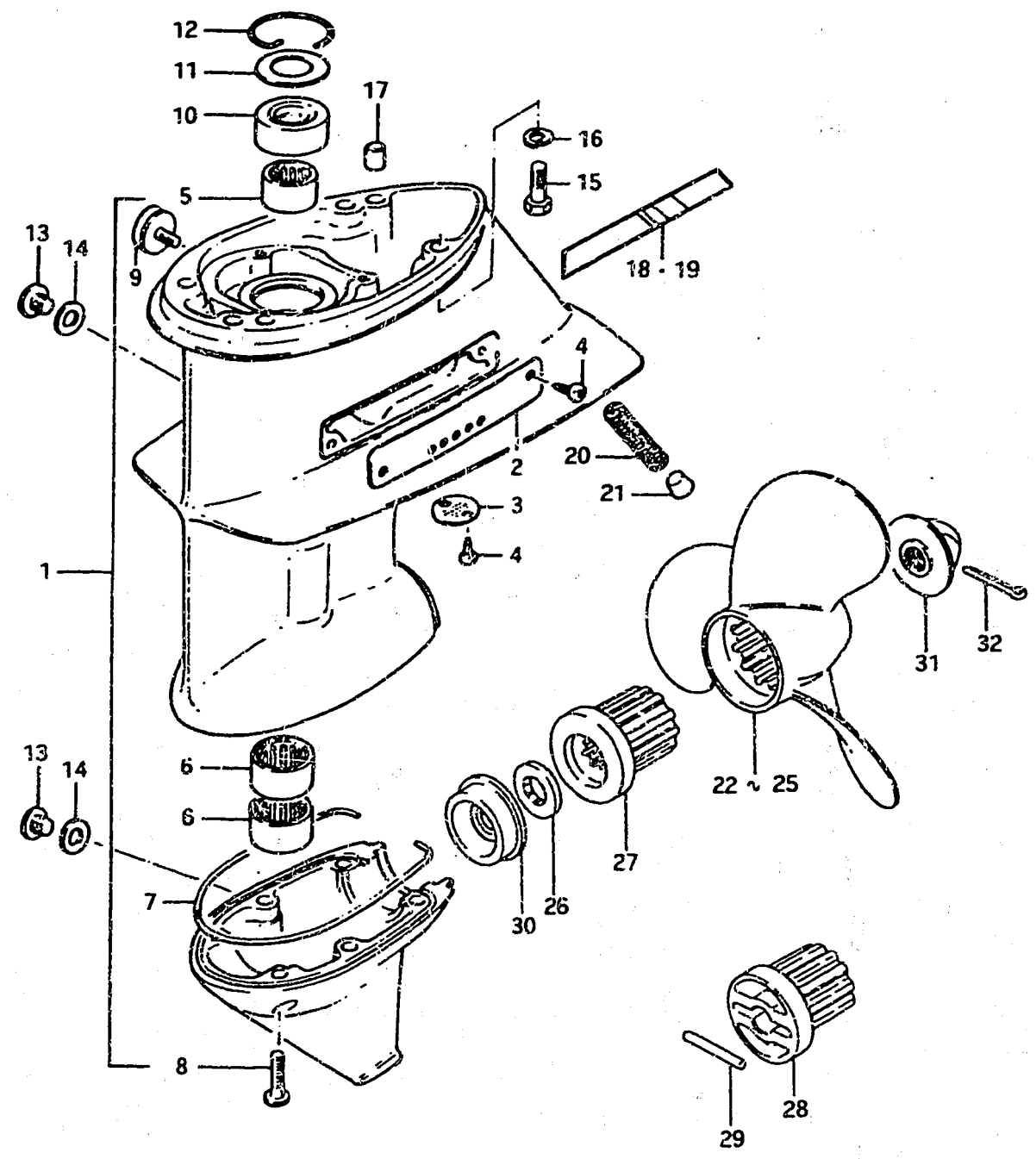

Ref. No.	Part No.	Description	Qty			Remarks
			C	D	F	
28	57613-93000	STOPPER, propeller bushing	1	1	1	
27-1	58120-93054	BUSHING, propeller	1	1	-	spline type to 58120-93023
27-2	58120-93023	BUSHING, propeller	-	1	1	
28-1	58120-93052	BUSHING, propeller	1	-	-	sherpin type E13 DT20 E37
28-2	58120-93052	BUSHING, propeller	1	1	-	
28-3	58120-93022	BUSHING, propeller	-	-	1	
29-1	09202-06017	SHEAR PIN (6x35)	1	1	1	
29-2	09202-06013	SHEAR PIN (6x35)	1	-	-	DT20 E37 to 09209-06035
29-3	09202-06019	SHEAR PIN (6x35)(SUS)	-	-	1	E13,OPT
30-1	09305-18001	BUSHING, shear pin	1	1	1	E13 to 56115-93000
30-2	09305-18001	BUSHING, shear pin	1	-	-	
30-3	56115-93000	COVER, bearing housing	-	-	1	
31	58131-93000	NUT, propeller	1	1	1	to 58130-93100
32	09204-03001	COTTER PIN	1	1	1	

FIG.48 (i-4) : DT25F E3, DT28F

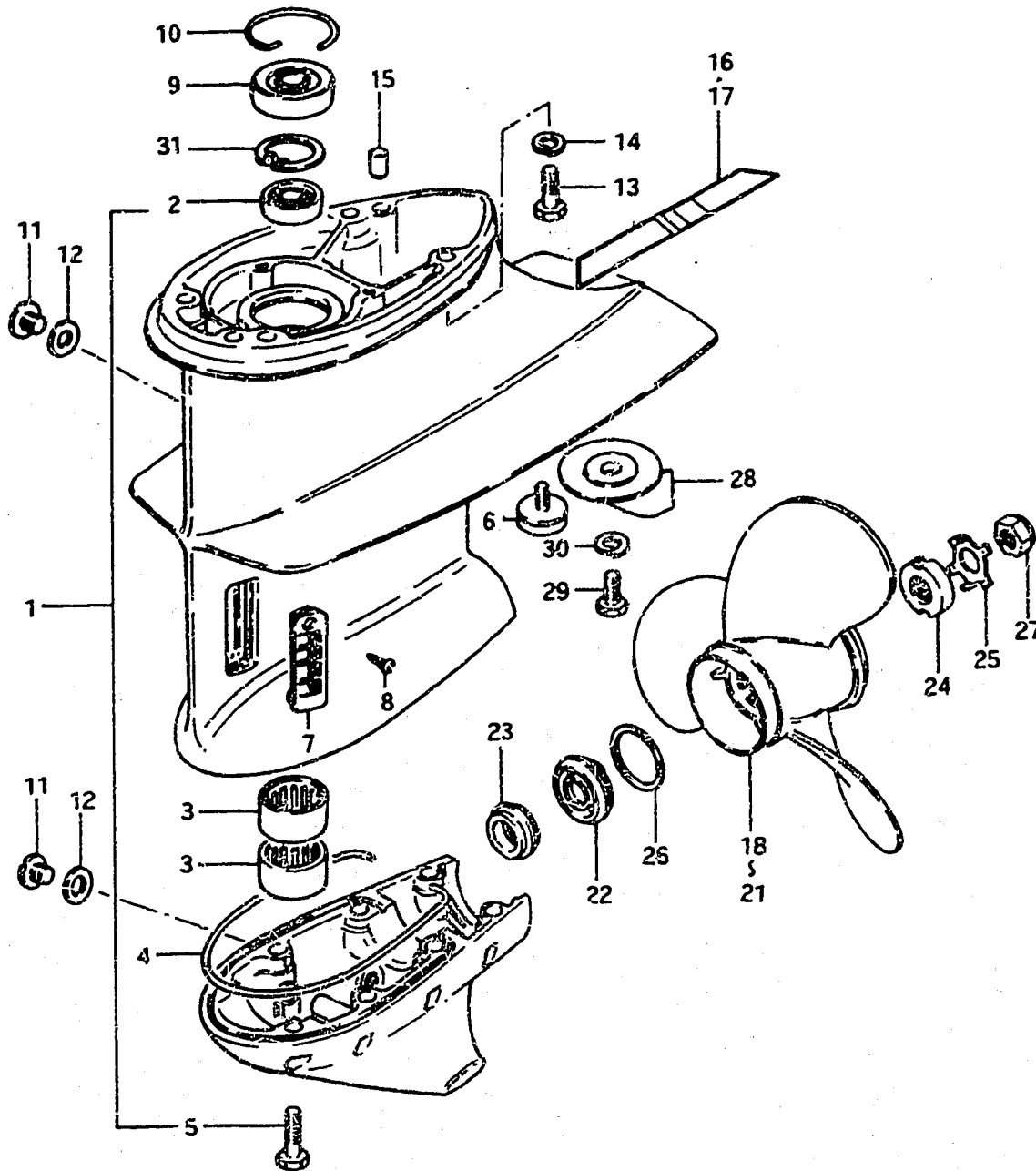

Ref. No.	Part No.	Description	F	Remarks
1	55100-93830-01J	CASE ASSY, gear	1	to 55100-93831-01J
2	08110-60030	•BEARING, driveshaft	1	
3	09263-24010	•BEARING, pinion (24x32x20)	2	
4-1	09280-00005	•SEAL, strip	1	to 55122-93400
4-2	55122-93400	•SEAL, strip	1	
5	09103-06003	•BOLT, lower gear case (6x25)	8	
6	55321-93141	•ZINC, protection	1	from 55321-93140
7	17631-93400	•FILTER, water	2	to 17631-93401
8	03142-04169	•SCREW	2	
9-1	09289-15005	OIL SEAL, gear case	1	to 09289-15007
9-2	09289-15007	OIL SEAL, gear case	1	
10	09387-44002	SET RING, gear case oil seal	1	
11	09248-10003	PLUG, drain	3	
12	09168-10004	GASKET, drain plug (10x17x2)	3	to 09168-10022
13	09100-08112	BOLT, gear case (8x30)	4	
14	09162-08003	LOCK WASHER, gear case	4	
15	09202-09002	DOWEL PIN, gear case	2	
16	55141-93400	EMBLEM, gear case side, RH	1	
17	55151-93400	EMBLEM, gear case side, LH	1	
18	58110-93400-01T	PROPELLER (L800)(3x9 1/4x8)	1	3x235x203.2
19	58110-93410-01T	PROPELLER (L900)(3x9 1/4x9)	1	3x235x228.6 L, LL, UL type, STD
20	58110-93430-01T	PROPELLER (L810)(3x9 1/4x8 1/2)	1	3x235x215.9
21	58110-93440-01T	PROPELLER (L910)(3x9 1/2x9 1/2)	1	3x241.3x241.3 S type, STD
22	57613-93400	STOPPER, propeller bushing	1	
23-1	56115-93400	COVER, bearing housing	1	to 56115-93401
23-2	56115-93401	COVER, bearing housing	1	
24	58135-93400	SPACER, propeller nut	1	to 58135-93401
25	58136-93400	LOCK WASHER, propeller nut	1	
26	09160-37004	WASHER, propeller bush stopper	1	
27	09159-14011	NUT, propeller	1	
28-1	55125-95201-01J	TRIM TUB	1	to 55125-95202-01J
28-2	55125-95202-01J	TRIM TUB	1	
29	09100-08090	BOLT	1	
30	09162-08003	LOCK WASHER	1	
31	08331-41358	CIRCLIP, gear case bearing	1	

FIG.47 (i-2, 3) : DT20, DT25

FIG.49

1 - 5

FIG.49 TRANSMISSION (DT20, DT25)

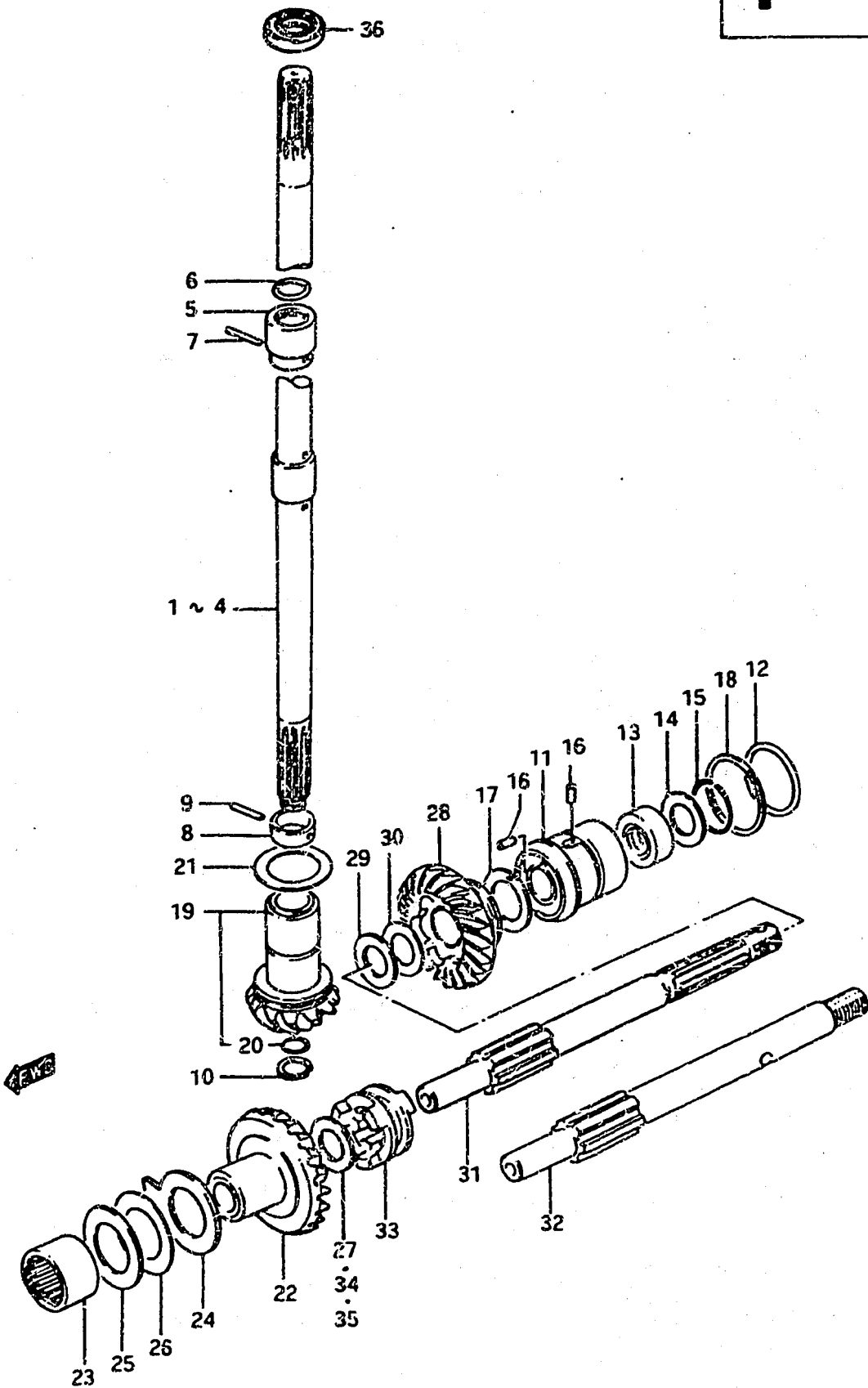

Ref. No.	Part No.	Description	Q'ty			Remarks
			C	D	F	
1	57110-93701	SHAFT, drive (L:684)	1	1	1	S type from 57110-93700
2	57110-93001	SHAFT, drive (L:803)	1	1	1	L type from 57110-93000
3	57110-93711	SHAFT, drive (L:854)	1	1	1	LL type from 57110-93710
4	57110-93721	SHAFT, drive (L:923)	1	1	1	UL type from 57110-93720
5	57116-93000	·SPACER, upper	1	1	1	
6	09280-15003	·O RING, upper spacer	1	1	1	d:2.4, ID:14.8
7	09205-02002	·PIN, upper spacer	1	1	1	
8	09180-15023	·SPACER, lower spacer stop	1	1	1	15x19.5x6
9	09205-02002	·PIN, lower spacer stop	1	1	1	
10	08331-31128	CIRCLIP, driveshaft	1	1	1	
11	55110-93000	HOUSING, bearing	1	1	1	
12	09280-32002	O RING, bearing housing	1	1	1	d:2.4, ID:14.8
13	09289-17002	OIL SEAL, bearing housing	1	1	1	17x30x9
14	09160-17014	WASHER, bearing housing	1	1	1	17x30x0.8 to 09160-18010
15	09381-28003	CIRCLIP, bearing housing	1	1	1	from 09381-30002
16	09205-03010	DOWEL PIN	2	2	2	
17	09160-19009	THRUST WASHER (19x32x1.5)	1	1	1	
18-1	09181-38002	SHIM (T:0.05)		AR		
18-2	09181-38003	SHIM (T:0.1)		AR		
18-3	09181-38004	SHIM (T:1.5)		AR		
18-4	09181-38005	SHIM (T:2.0)		AR		
19	57310-93005	PINION (NT:12)	1	1	1	from 57300-93813
20	09381-12002	·CIRCLIP, pinion	1	1	1	
21	08221-25352	SHIM, pinion (T:0.05)		AR		
22-1	57510-93002	GEAR, forward	1	-	-	~DT25C-11352, ~DT20C-10928
22-2	57510-93003	GEAR, forward	1	1	-	(NT:21)
22-3	57510-93005	GEAR, forward	-	-	1	to 57510-93006
23	09263-24010	BEARING, forward gear	1	1	1	
24	57515-93000	THRUST WASHER, forward gear	1	1	1	

FIG.50 (i-7, 8) : DT25F E3, DT28F



FIG.49

1 - 6

FIG.49 TRANSMISSION (DT20, DT25)

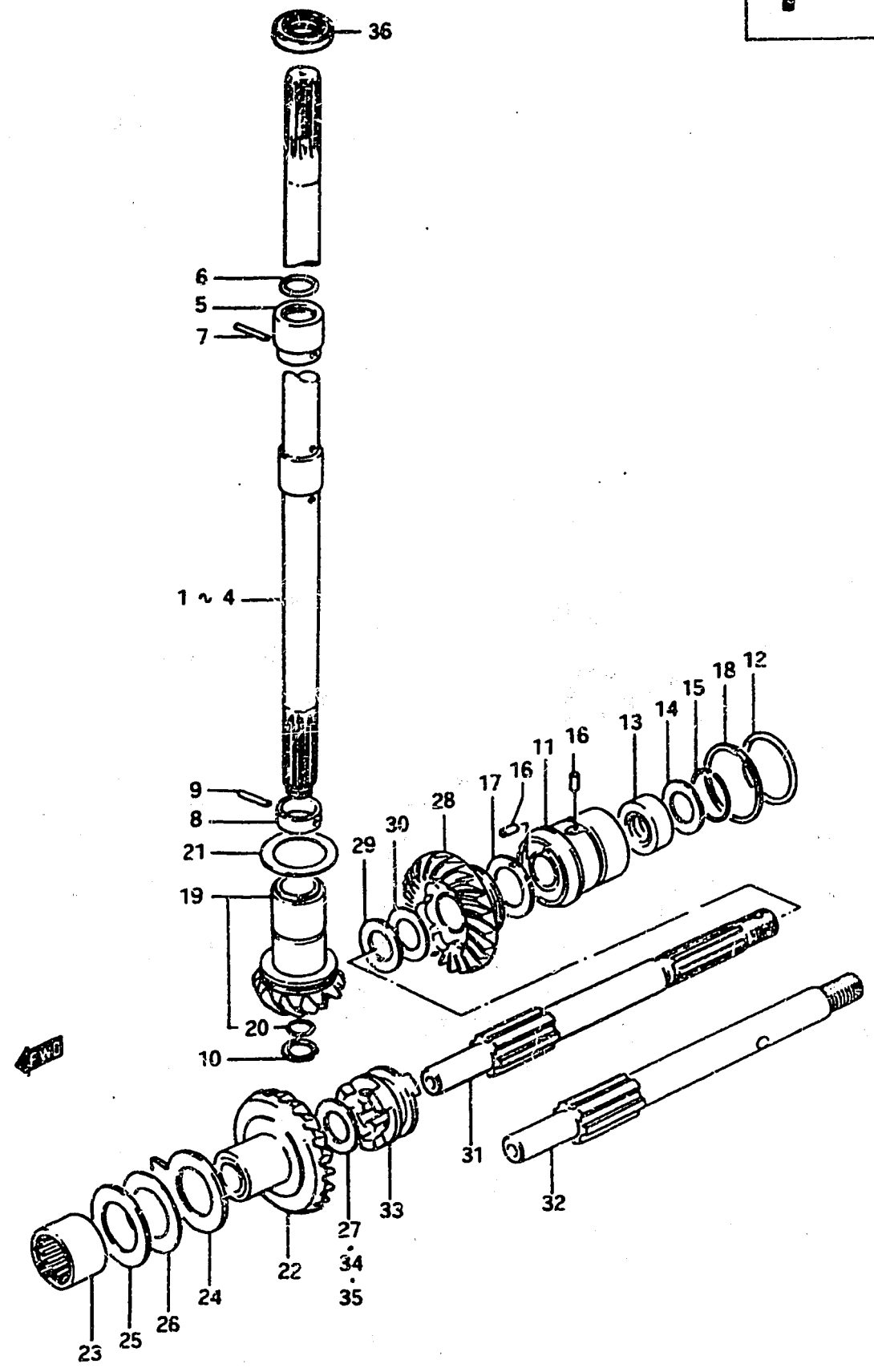

DT20, DT25, DT28F

Ref. No.	Part No.	Description	Q'ty			Remarks
			C	D	F	
25-1	08211-25443	SHIM (T:2.0)		AR		
25-2	08211-25442	SHIM (T:1.5)		AR		
26-1	09181-25004	SHIM (T:0.1)		AR		
26-2	09181-25005	SHIM (T:0.05)		AR		
27-1	08211-17283	WASHER (T:2.0)	1	-	-	~DT25C-11352
27-2	08211-17242	WASHER (T:1.5)	1	1	-	~DT20C-10928
28-1	57520-93002	GEAR, reverse	1	-	-	~DT25C-11352 ~DT20C-10928
28-2	57520-93003	GEAR, reverse	1	1	-	(NT:21) to 57520-93004
28-3	57520-93004	GEAR, reverse	-	-	1	
29-1	08211-17283	WASHER (T:2.0)	AR	-	-	~DT25C-11352,
29-2	08211-17282	WASHER (T:1.5)	AR	-	-	~DT20C-10928
29-3	08211-17242	WASHER (T:1.5)		AR		
29-4	08211-17245	WASHER (T:2.5)		AR		
29-5	08211-17241	WASHER (T:1.0)	-	-	AR	
30-1	08221-17283	SHIM (T:0.1)	AR	-	-	~DT25C-11352, ~DT20C-10928
30-2	08221-17243	SHIM (T:0.1)		AR		
30-3	08221-17245	SHIM (T:0.5)	-	-	AR	
31-1	57611-93001	SHAFT, propeller	1	1	-	spline type
31-2	57610-93020	SHAFT, propeller	-	-	1	
32-1	57611-93000	SHAFT, propeller	1	1	-	DT20(C)E37, DT20 (C,D)E13, DT25(C,D)E13
32-2	57610-93010	SHAFT, propeller	-	-	1	E13
33-1	57621-93002	SHIFTER, clutch dog	1	-	-	~DT25C-11352 ~DT20C-10928
33-2	57621-93003	SHIFTER, clutch dog	1	1	-	to 57621-93004 ~DT20D-10699
33-3	57621-93004	SHIFTER, clutch dog	-	1	-	to 57621-93005
33-4	57621-93400	SHIFTER, clutch dog	-	-	1	to 57621-93401
34-1	08211-16202	WASHER, forward gear	-	-	1	(T:1.5)
34-2	08211-16201	WASHER, forward gear	-	-	AR	(T:1.0)
35	08221-16203	SHIM, forward gear	-	-	AR	(T:0.1)
36	09289-15004	OIL SEAL, drive shaft	-	-	1	to 09289-15009 (15x25x7)

FIG.50 (i-7, 8) : DT25F E3, DT28F

DT20, DT25, DT28F

FIG. 50

1 - 7

FIG. 50 TRANSMISSION (DT25FE3, DT28F)

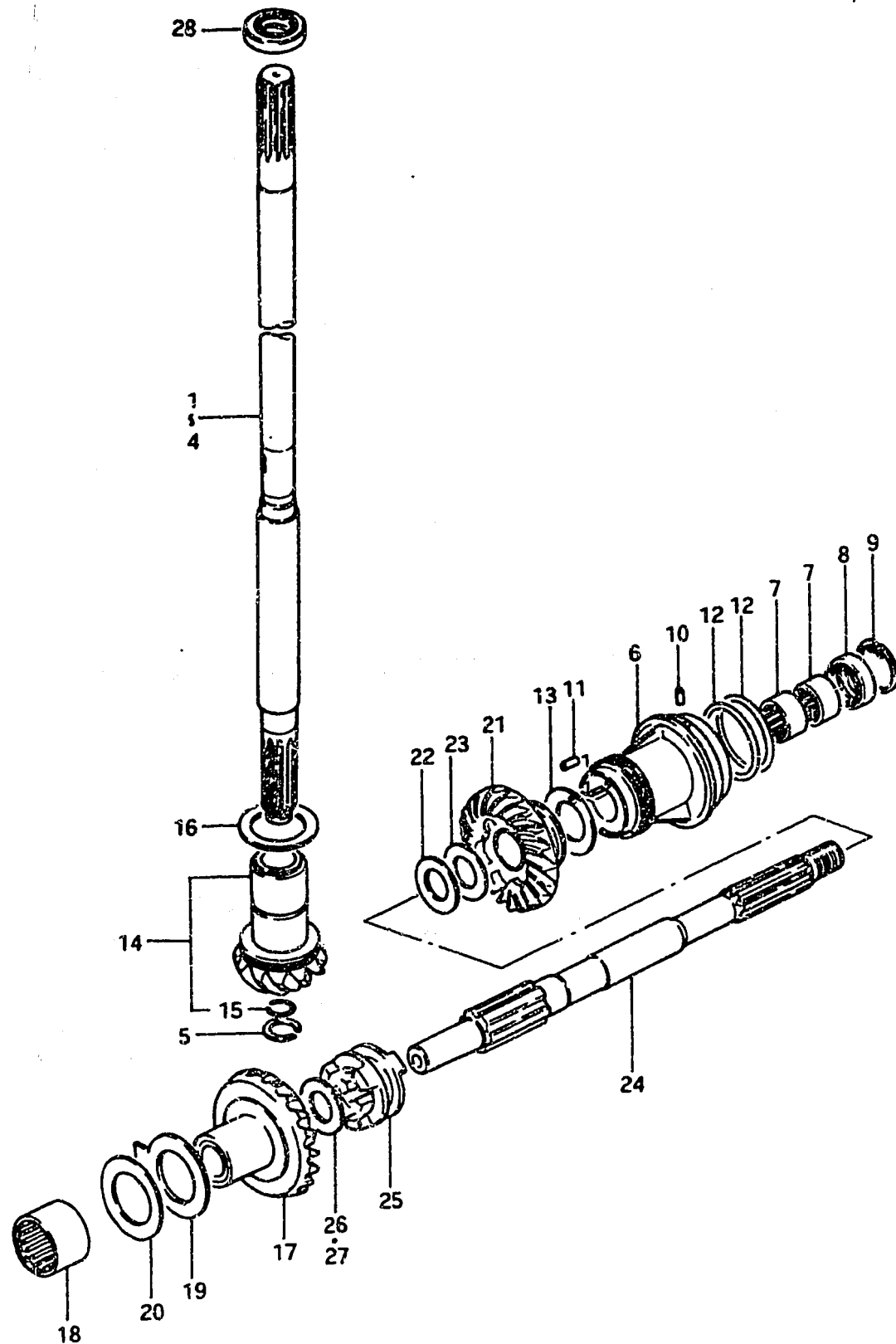

Ref. No.	Part No.	Description	Q'ty	F	Remarks
1	57110-93411	SHAFT, drive (L:711)	1	1	S type from 57110-93410
2	57110-93401	SHAFT, drive (L:830)	1	1	L type from 57110-93400
3	57110-93421	SHAFT, drive (L:881)	1	1	LL type from 57110-93420
4	57110-93431	SHAFT, drive (L:950)	1	1	UL type from 57110-93430
5	08331-31128	CIRCLIP, driveshaft	1		
6-1	56100-93810	HOUSING SET, bearing (Incl. Ref. No. 7~8)	1	1	to 56100-93811
6-2	56100-93811	HOUSING SET, bearing (Incl. Ref. No. 7~11)	1	1	to 56100-93812
6-3	56100-93812	HOUSING SET, bearing	1		
7	09263-17009	BEARING, housing	2		
8	09289-17002	OIL SEAL, bearing housing	1	1	to 09289-17004
9	09387-28003	(-)SNAP RING, bearing housing	1		
10	09202-04008	(-)PIN, bearing housing	1		
11	09205-03010	(-)PIN, thrust washer	1		
12	09280-40004	O RING, bearing housing	2		
13-1	09160-19011	THRUST WASHER (T:2.0)	AR		
13-2	09160-19012	THRUST WASHER (T:2.5)	AR		
13-3	09160-19013	THRUST WASHER (T:3.0)	AR		
13-4	09160-19014	THRUST WASHER (T:3.5)	AR		
14	57310-93005	PINION SET	1	1	from 57300-93813
15	09381-12002	CIRCLIP, pinion	1		
16	08221-25352	SHIM, pinion (T:0.05)	AR		
17	57510-93005	GEAR, forward (NT:21)	1	1	to 57510-93006
18	09263-24010	BEARING, forward gear	1		
19	57515-93000	THRUST WASHER, forward gear	1		
20-1	08211-25443	SHIM (T:2.0)	AR		
20-2	08211-25442	SHIM (T:1.5)	AR		
20-3	09181-25004	SHIM (T:0.1)	AR		
20-4	09181-25005	SHIM (T:0.05)	AR		
21	57520-93004	GEAR, reverse (NT:21)	1		
22-1	08211-17242	WASHER (T:1.5)	AR		
22-2	08211-17241	WASHER (T:1.0)	AR		

FIG. 49 (i-5, 6) : DT20, DT25

FIG. 50

1 - 8

FIG. 50 TRANSMISSION (DT25FE3, DT28F)

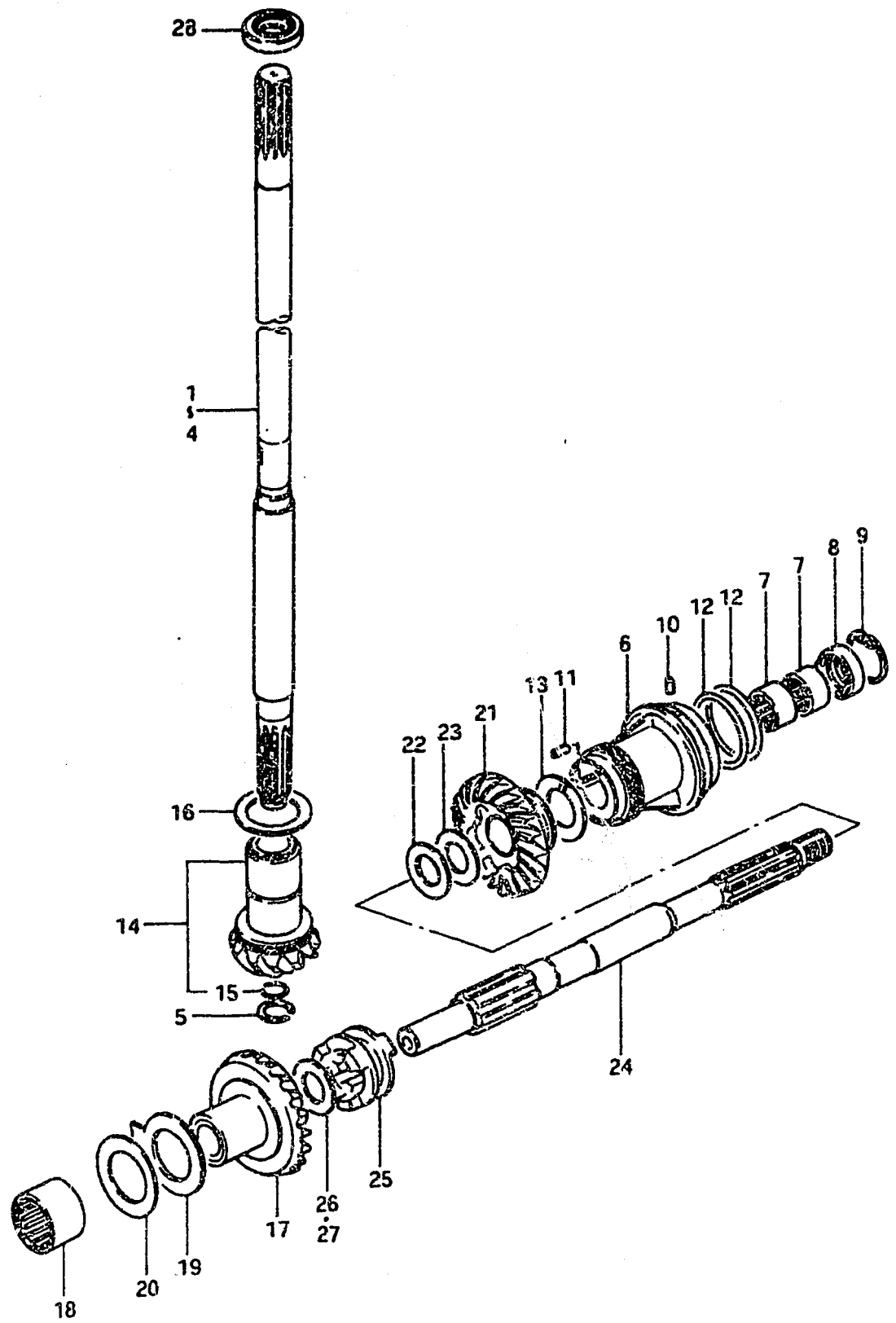

Ref. No.	Part No.	Description	Q'ty	F	Remarks
23-1	08221-17243	SHIM (T:0.1)		AR	
23-2	08221-17245	SHIM (T:0.5)		AR	
24	57610-93401	SHAFT, propeller	1		to 57610-93402
25	57621-93400	SHIFTER, clutch dog	1		to 57621-93401
26-1	08211-16202	WASHER, forward gear (T:1.5)	1		
26-2	08211-16201	WASHER, forward gear (T:1.0)	AR		
27	08221-16203	SHIM, forward gear (T:0.1)	AR		
28	09289-15004	OIL SEAL, drive shaft (15x25x7)	1		to 09289-15009

FIG. 49 (i-5, 6) : DT20, DT25

FIG. 51

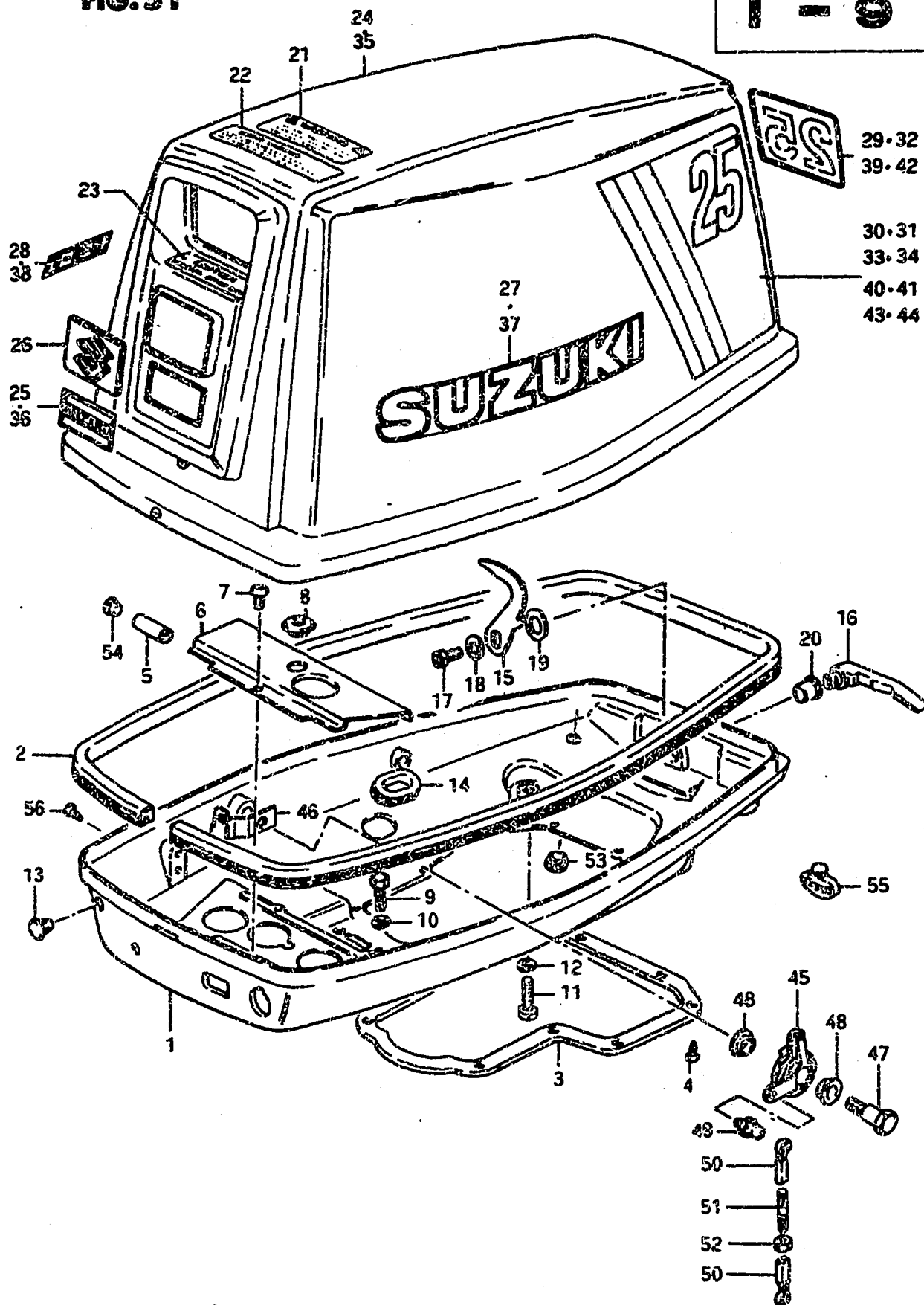

DT20, DT25, DT28F

FIG. 51 ENGINE COVER (DT20, DT25)

Ref. No.	Part No.	Description	Q'ty			Remarks
			C	D	F	
1-1	61110-93300-01J	COVER, engine lower	1	-	-	to 61110-93301-01J
1-2	61110-93301-01J	COVER, engine lower to (61110-93302-01J)+(65720-98500)+(08310-22108)+(65750-98500)	-	1	-	
1-3	61110-93302-01J	COVER, engine lower DT20D-10700~, DT25D-11988~	-	1	-	
1-4	61110-93400-01J	COVER, engine lower	-	-	1	to 61110-93401-01J
2	61112-93000	•RUBBER, lower cover	1	1	1	to 61112-93400
3	61113-93000	•SEAL, lower cover	1	1	1	
4	09229-03007	•RIVET, lower cover seal	10	10	10	
5	61118-93400	•BUSH, remote control shaft	-	-	1	8x12x33.5
6-1	61121-93000	COVER, air inlet	1	1	-	
6-2	61121-93400-01J	COVER, air inlet	-	-	1	
7	02112-04108	SCREW	3	3	3	
8	09250-12001	PLUG, inlet cover	-	-	1	
9	09100-06020	BOLT, lower cover No.1	2	2	2	6x20
10	09162-06001	LOCK WASHER, lower cover	2	2	2	
11	09100-08112	BOLT, lower cover No.2	2	2	2	8x30
12	09162-08003	LOCK WASHER, lower cover	2	2	2	
13	09250-11003	CAP, lower cover	2	2	-	
14	09308-12007	GROMMET, lower cover	1	1	1	
15	61631-96001	HGOK, lower cover	1	1	1	
16-1	61633-96001-01J	LEVER, hook ~DT20D-11222	1	1	-	to 61633-96002-01J
16-2	61633-96002-01J	LEVER, hook	-	1	1	
17	01107-06103	BOLT	1	1	1	
18	08322-21033	WASHER	1	1	1	
19	09164-13001	WAVE WASHER	1	1	1	
20	09306-13002	BUSHING, hook lever	1	1	1	
21-1	61457-93000	MARK, warning	1	1	-	to 61457-93001
21-2	61457-93001	MARK, warning	-	1	1	
22-1	61458-95200	MARK, safety warning	1	1	-	to 61458-95201
22-2	61458-95201	MARK, safety warning	-	1	1	
23-1	61459-93300	MARK, neutral caution	-	1	-	to 61459-93301
23-2	61459-93301	MARK, neutral caution	-	1	1	E3

FIG. 52 (i-11, 12) : DT28F

DT20, DT25, DT28F

FIG.51

I - 10

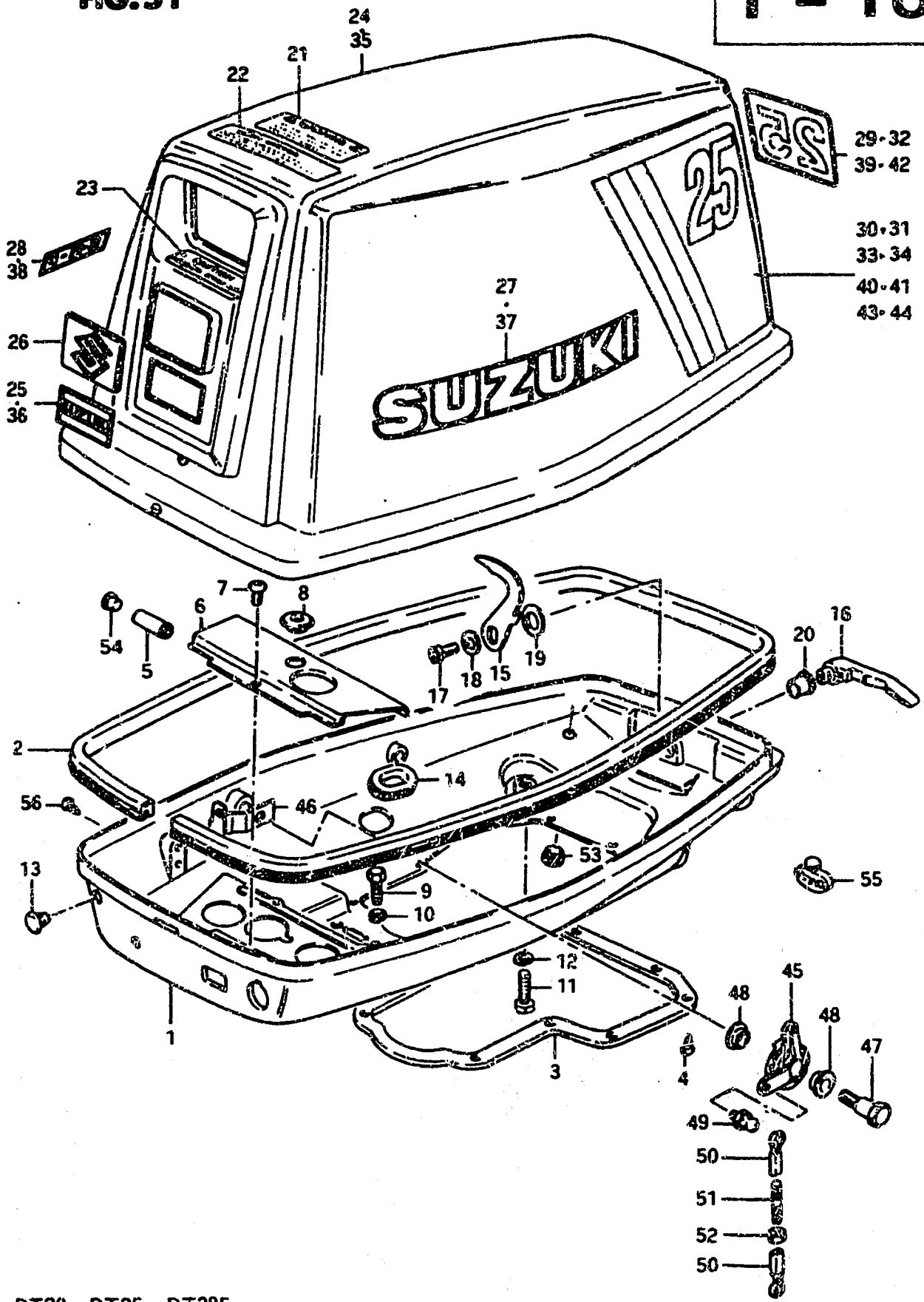

DT20, DT25, DT28F

FIG.51 ENGINE COVER (DT20, DT25)

Ref. No.	Part No.	Description	Q'ty			Remarks
			C	D	F	
24	61400-93841-01T	COVER SET, engine	1	1	*1	*for Hand Starter to 61400-93842-01T
25	61422-93300	·MARK, emblem front "SUZUKI"	1	1	*1	
26	61424-93100	·MARK, emblem front "S"	1	1	*1	
27	61441-95200	·EMBLEM, engine cover "SUZUKI"	2	2	*2	to 61441-94300
28-1	21131-96000	·MARK, clutch shifting (English Only)	1	1	*-	
28-2	21131-96001	·MARK, clutch shifting (English + French)	-	1	*1	to 21131-96002
29	61435-93002	MARK, emblem rear "25"	1	1	*1	
30	61443-93001	DECAL, engine cover RH "25"	1	1	*1	DT25
31	61453-93001	DECAL, engine cover LH "25"	1	1	*1	
32	61435-93601	MARK, emblem rear	1	1	*1	
33	61443-93002	DECAL, engine cover RH	1	1	*1	DT20
34	61453-93002	DECAL, engine cover LH	1	1	*1	
35	61400-93870-01T	COVER SET, engine	-	-	1	to 61400-93871-01T
36	61422-93400	·MARK, emblem front "SUZUKI"	-	-	1	to 61422-93401
37	61441-95200	·EMBLEM, engine cover "SUZUKI"	-	-	2	to 61441-94300
38	21131-96001	·MARK, clutch shifting to 21131-96002	-	-	1	for Electric Starter
39	61435-93400	MARK, emblem rear "25"	-	-	1	
40	61443-93400	DECAL, engine cover RH "25"	-	-	1	
41	61453-93400	DECAL, engine cover LH "25"	-	-	1	
42	61435-93410	MARK, emblem rear	-	-	1	DT20
43	61443-93410	DECAL, engine cover RH	-	-	1	for Electric Starter
44	61453-93410	DECAL, engine cover LH	-	-	1	
45	19171-93400-01J	LEVER, throttle	-	-	1	
46	19174-93400	BRACKET, throttle cable	-	-	1	
47	09111-08038	BOLT, throttle lever	-	-	1	
48	09306-12005	BUSH, throttle lever	-	-	2	
49	09119-06047	BALL, pivot	-	-	2	from 09119-06039
50	67463-95200	CONNECTOR, throttle	-	-	2	
51	19179-93400	ROD	-	-	1	
52	09140-05001	NUT	-	-	1	
53	09250-08003	CAP, shear pin holder hole	-	-	1	
54	09250-08001	CAP, remote control shaft	-	-	1	
55	61521-96000	HOLDER, shear pin	1	1	1	DT20(C)E37, DT20/DT25 E13
56	09229-06003	RIVET, lower cover	-	-	3	

DT20, DT25, DT28F

FIG.52 (i-11, 12) : DT28F

FIG. 52

1 - 11

FIG. 52 ENGINE COVER (DT28F)

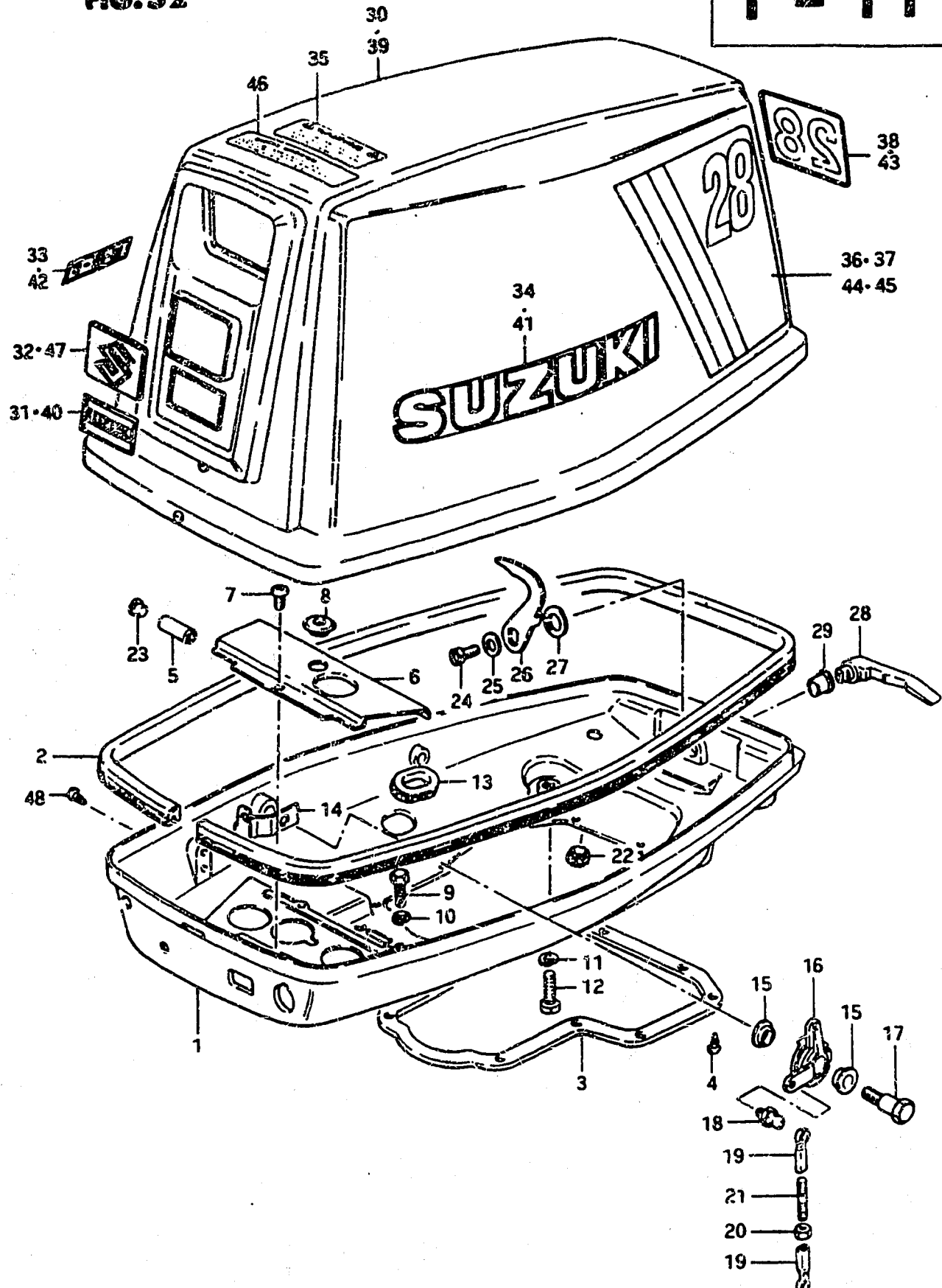

Ref. No.	Part No.	Description	Q'ty	F	Remarks
1	61110-93401-01J	COVER, engine lower	1		to 61110-93401-01J
2	61112-93000	-RUBBER, lower cover	1		to 61112-93400
3	61113-93000	-SEAL, lower cover	1		
4	09229-03007	-RIVET, lower cover seal	10		
5	61118-93400	BUSH, remote control shaft	1		8x12x33.5
6	61121-93400-01J	COVER, air inlet	1		
7	02112-04108	SCREW	3		
8	09250-12001	PLUG, inlet cover	1		
9	09100-06020	BOLT 1 (6x20)	2		
10	09162-06001	LOCK WASHER	2		
11	09162-08003	LOCK WASHER	2		
12	09100-08112	BOLT 2 (8x30)	2		
13	09308-12007	GROMMET, lower cover	1		
14	19174-93400	BRACKET, throttle cable	1		
15	09306-12005	BUSH, throttle lever	1		
16	19171-93400-01J	LEVER, throttle lever	1		
17	09111-08038	BOLT, throttle lever	1		
18	09119-06047	BALL, pivot	2		from 09119-06039
19	67463-95200	CONNECTOR, throttle	2		
20	09140-05001	NUT	1		
21	19179-93400	ROD	1		
22	09250-08003	CAP, shear pin holder hole	1		
23	09250-08001	CAP, remote control shaft	1		
24	01107-06108	BOLT	1		
25	08322-21068	WASHER	1		
26	61631-96001	HOOK, lower cover	1		
27	09164-13001	WASHER, wave	1		
28	61633-96002-01J	LEVER, hook	1		
29	09306-13002	BUSH	1		

The model name F of this page means DT28F only.  
 FIG. 51 (i-9, 10) : DT20, DT25

FIG. 52

1 - 12

FIG. 52 ENGINE COVER (DT28F)

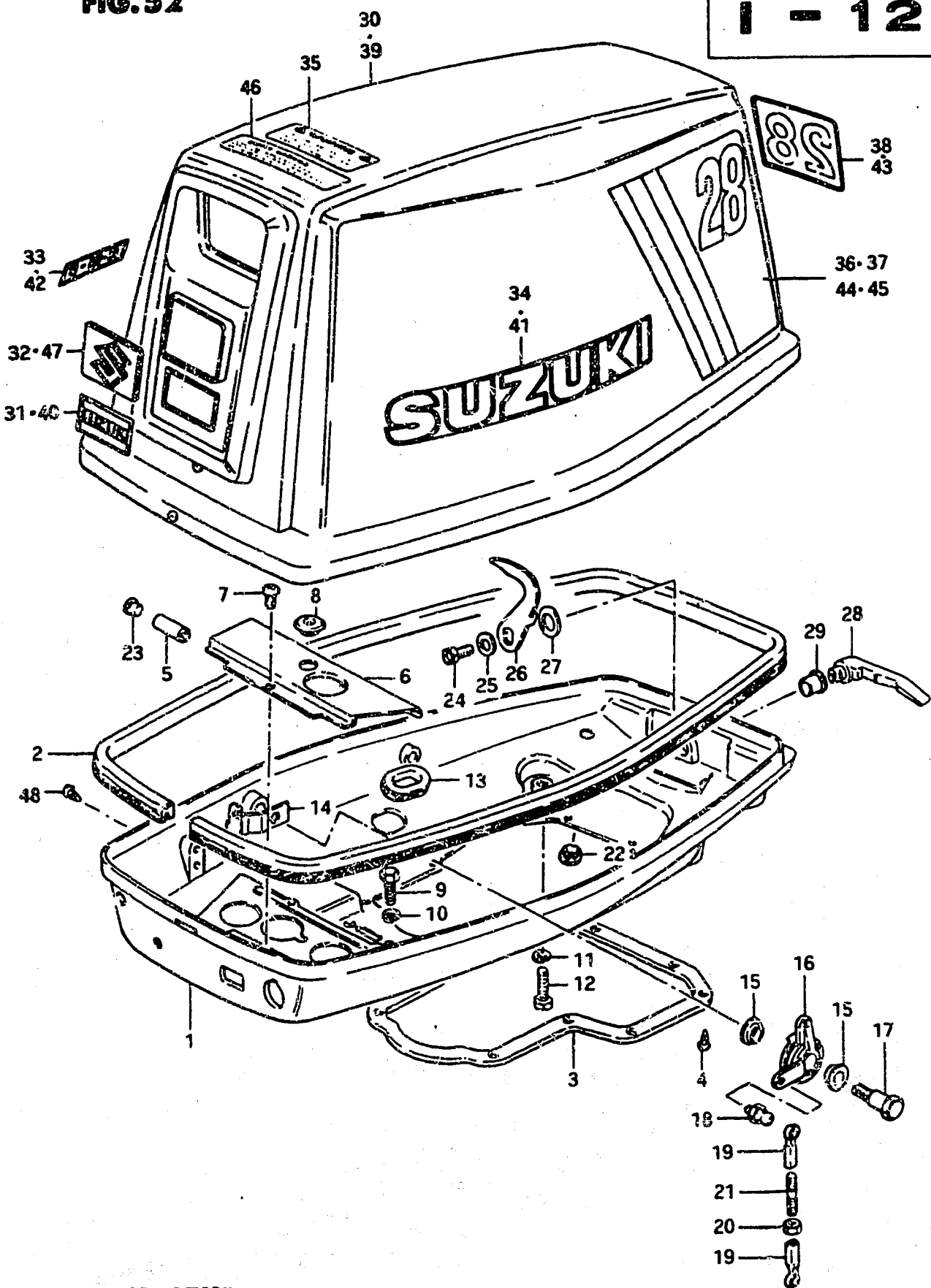

Ref. No.	Part No.	Description	Q'ty	F	Remarks
30-1	61400-93841-01T	COVER SET, engine (Incl. Ref. No. 31~34)	1	1	to 61400-93842-01T
30-2	61400-93842-01T	COTER SET, engine (Incl. Ref. No. 32~34)	1	1	to 61400-93843-01T
31	61422-93300	·MARK, emblem front "SUZUKI"	1	1	
32	61424-93100	·MARK, emblem front "S"	1	1	to 61424-93400
33	21131-96001	·MARK, emblem shift	1	1	English+French to 21131-96002
34	61441-95200	·EMBLEM, side (to 61441-94300)	2	2	for Hand Starter
35	61457-93001	MARK, warning	1	1	
36	61443-93430	DECAL, side RH "28"	1	1	
37	61453-93430	DECAL, side LH "28"	1	1	
38	61435-93430	MARK, emblem rear	1	1	
39	61400-93870-01T	COVER SET, engine	1	1	to 61400-93871-01T
40	61422-93400	·MARK, emblem front "SUZUKI"	1	1	to 61422-93401
41	61441-95200	·EMBLEM, side	2	2	to 61441-94300
42	21131-96001	·MARK, clutch shift to 21131-96002	1	1	for Electric Starter
43	61435-93420	MARK, emblem rear "28"	1	1	
44	61453-93420	DECAL, side LH "28"	1	1	
45	61443-93420	DECAL, side RH "28"	1	1	
46	61458-95201	MARK, safety warning	1	1	
47	61424-93410	MARK, emblem front	1	1	for 61400-93842-01T
48	09229-06003	RIVET, lower cover	3	3	

The model name F of this page means DT28F only.  
 FIG. 51 (i-9, 10) : DT20, DT25

FIG. 53

1 - 13

FIG.53 HANDLE (model C, D)

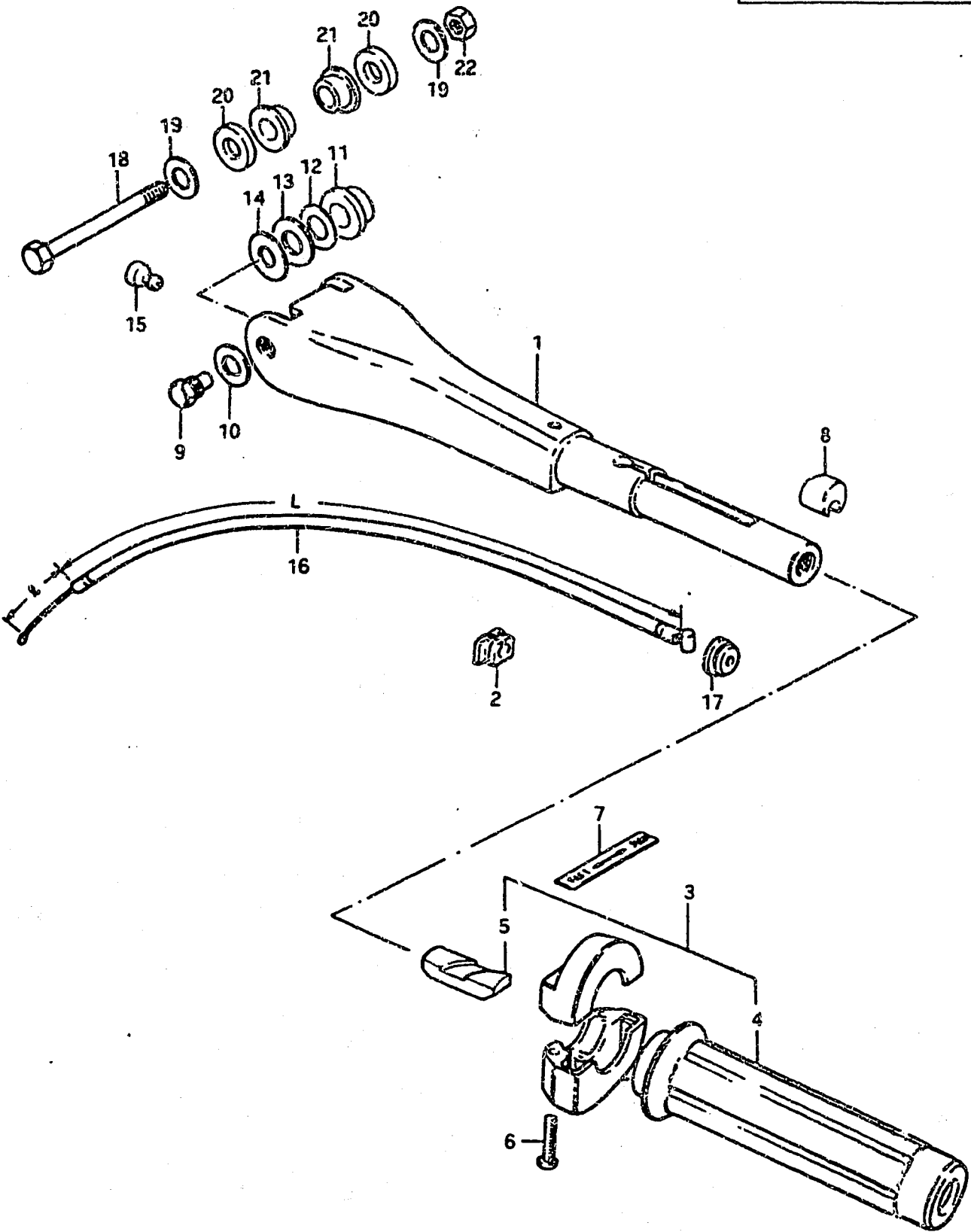

Ref. No.	Part No.	Description	Qty		Remarks
			C	D	
1	63111-93300-01J	HANDLE, tiller	1	1	
2	53112-93103	GROMMET	1	1	
3	63200-93101	GRIP ASSY, throttle	1	1	to 63200-93102
4	63210-93101	GRIP, throttle	1	1	to 63210-93102
5	63214-93100	PIECE, sliding	1	1	
6	63218-93100	SCREW, cover	2	2	
7	63215-93100	MARK, handle grip	1	1	to 63215-93101
8	63331-93100	FRICTION, handle	1	1	to 63331-93101
9	09119-12004	BOLT, handle pivot	2	2	
10	09160-12033	WASHER, handle (12.5x22x2.3)	2	2	
11	09305-10004	BUSHING, handle pivot	2	2	
12	09160-10027	WASHER, pivot bushing	AR		10.5x24x0.5
13	09160-10041	WASHER, pivot (10.3x25x1.5)	AR		
14	09164-12012	WAVE WASHER	AR		
15	09321-07001	CUSHION, handle	1	1	
16	63510-93300	CABLE ASSY, throttle	1	1	L:520, l:64
17	09308-05010	GROMMET, throttle cable	1	1	
18	09100-10115	BOLT, handle pivot (10x75)	-	1	} DT20D-12293~ DT25D-14398~
19	09160-10040	WASHER (10.5x18x1.6)	-	2	
20	09160-10027	WASHER (10.5x24x0.5)	-	2	
21	09305-10007	BUSH	-	2	
22	09140-10017	NUT	-	1	

FIG.54 (1-14) : model F



FIG. 54

I - 14

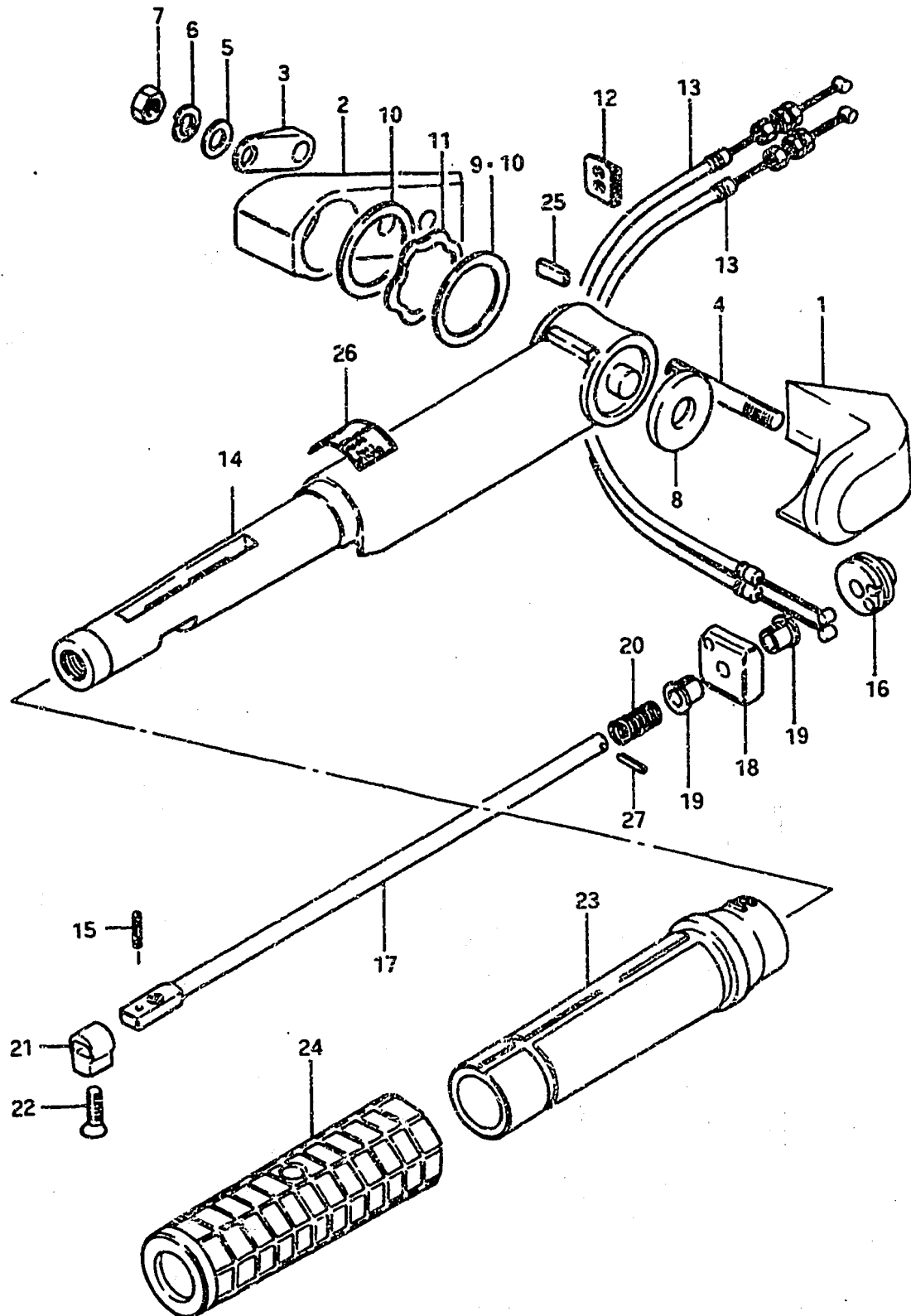

FIG. 54 HANDLE (model F)

Q'ty

Ref. No.	Part No.	Description	F	Remarks
1	63121-93400-01J	COVER, tiller handle	1	to 63121-93401-01J
2	63123-93400-01J	BLOCK	1	
3	63124-93401-01J	SPACER	1	
4	09108-08063	STUD BOLT	2	
5	09160-08015	WASHER (8.5x16x1.6)	2	
6	09162-08003	LOCK WASHER	2	
7	09140-08003	NUT	2	
8	63114-93200	SPACER (14x31x3.5)	1	
9	09160-32007	WASHER (32.5x42x0.2)	AR	
10	09160-32004	WASHER (32.5x42x0.5)	2	
11	09164-32001	WAVE WASHER	1	
12	09309-06006	GROMMET, throttle cable	1	
13	63610-93400	CABLE ASSY, throttle (grip+lever)	2	
14	63111-93400-01J	HANDLE, tiller	1	to 63111-93401-01J
15	63227-93200	PIN, handle rod (L:14)	1	
16	63222-93200	DRUM, handle rod	1	
17	63221-93400	ROD, handle	1	
18	63224-93202	PROTECTOR, stop switch wire	1	from 63224-93201
19	63225-93200	BUSH	2	
20	63226-93200	SPRING	1	
21	63223-93200	STOPPER	1	
22	09126-06004	SCREW (6x20)	1	
23	63211-93200	GRIP, handle	1	to 63210-93200
24	63212-93200	RUBBER, handle grip	1	
25	63117-93400	PROTECTOR, stop switch wire	1	
26	63215-93400	MARK, handle grip	1	
27	09205-03004	PIN, handle rod drum (L:20)	1	

FIG. 53 (i-13) : model C, D

FIG.55

K - 2

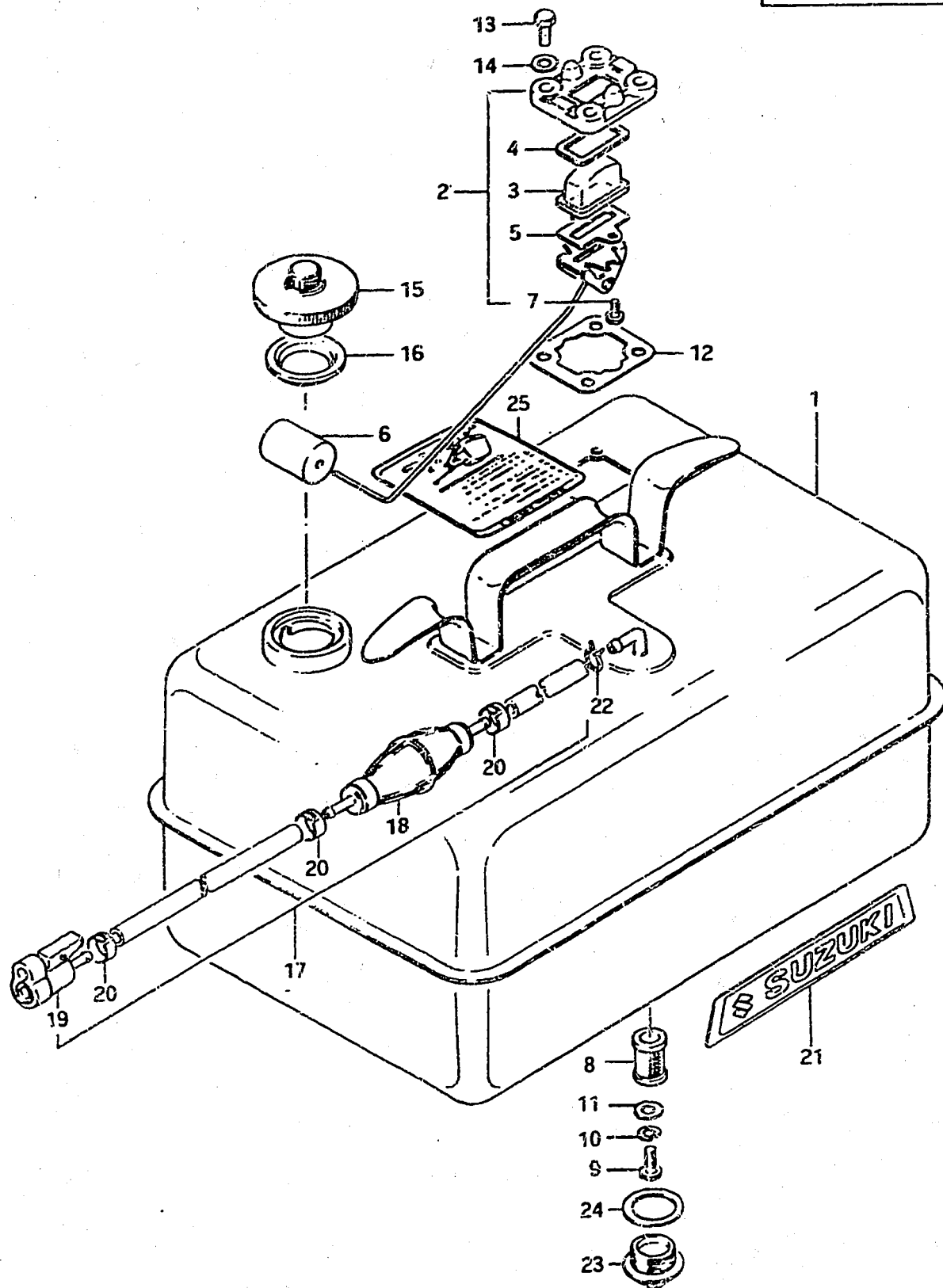

FIG.55 FUEL TANK 1

Ref. No.	Part No.	Description	Q'ty		Remarks
			C	D	
1-1	65800-93814	TANK ASSY, fuel to 65800-93816	1	-	23ℓ (6 U.S. GAL.) (5 IMP. GAL.)
1-2	65800-93816	TANK ASSY, fuel to (65800-93830)+(65750-99700)	-	1	23ℓ (6 U.S. GAL.) (5 IMP. GAL.)
2	65850-93000	·GAUGE, fuel	1	1	
3-1	65853-93000	··STRAINER (to 65853-93001)	1	-	
3-2	65853-93001	··STRAINER	-	1	
4	65854-93000	··GASKET, strainer	1	1	to 65854-93001
5	65862-93000	··GASKET, float arm holder	1	1	
6	65864-93000	··FLOAT	1	1	
7	02112-04108	··SCREW	2	2	
8	65830-93300	·FILTER (to 65830-93301)	1	1	
9	02112-05088	·SCREW	1	1	
10	08321-21058	·LOCK WASHER	1	1	
11	08322-21058	·WASHER	1	1	DT9.9C,DT9.9D
12	65871-93000	·GASKET, fuel gauge	1	1	DT14C,DT14D
13	01107-06168	·BOLT	4	4	DT16C,DT16D
14	08322-21068	·WASHER	4	4	DT20C,DT20D
15	65510-96000	·CAP, fuel tank	1	1	DT25C,DT25D
16	44248-12000	·GASKET, tank cap	1	1	
17	65700-99702	·HOSE ASSY, fuel to 65700-99704	1	1	
18	65770-99700	··PUMP, squeeze to 65770-99701	1	1	
19	65750-99700	··SOCKET, fuel hose	1	1	
20	09401-13402	··CLIP	3	3	
21	65312-99701	·EMBLEM, fuel tank to 61441-98400	2	2	
22	09401-11402	·CLIP	1	1	
23	09247-25001	·PLUG, fuel drain	1	1	
24	09168-25002	·GASKET, drain plug	1	1	25x35x1
25-1	61511-93601	MARK, starter indicator to 61511-93602	1	-	
25-2	61511-93602	MARK, starter indicator	-	1	

FIG.56 (K-3) : (C, D)E13, CE37  
 FIG.57 (K-4) : DE3  
 FIG.58 (K-5) : model F

FIG. 56

K - 3

FIG. 56 FUEL TANK 2

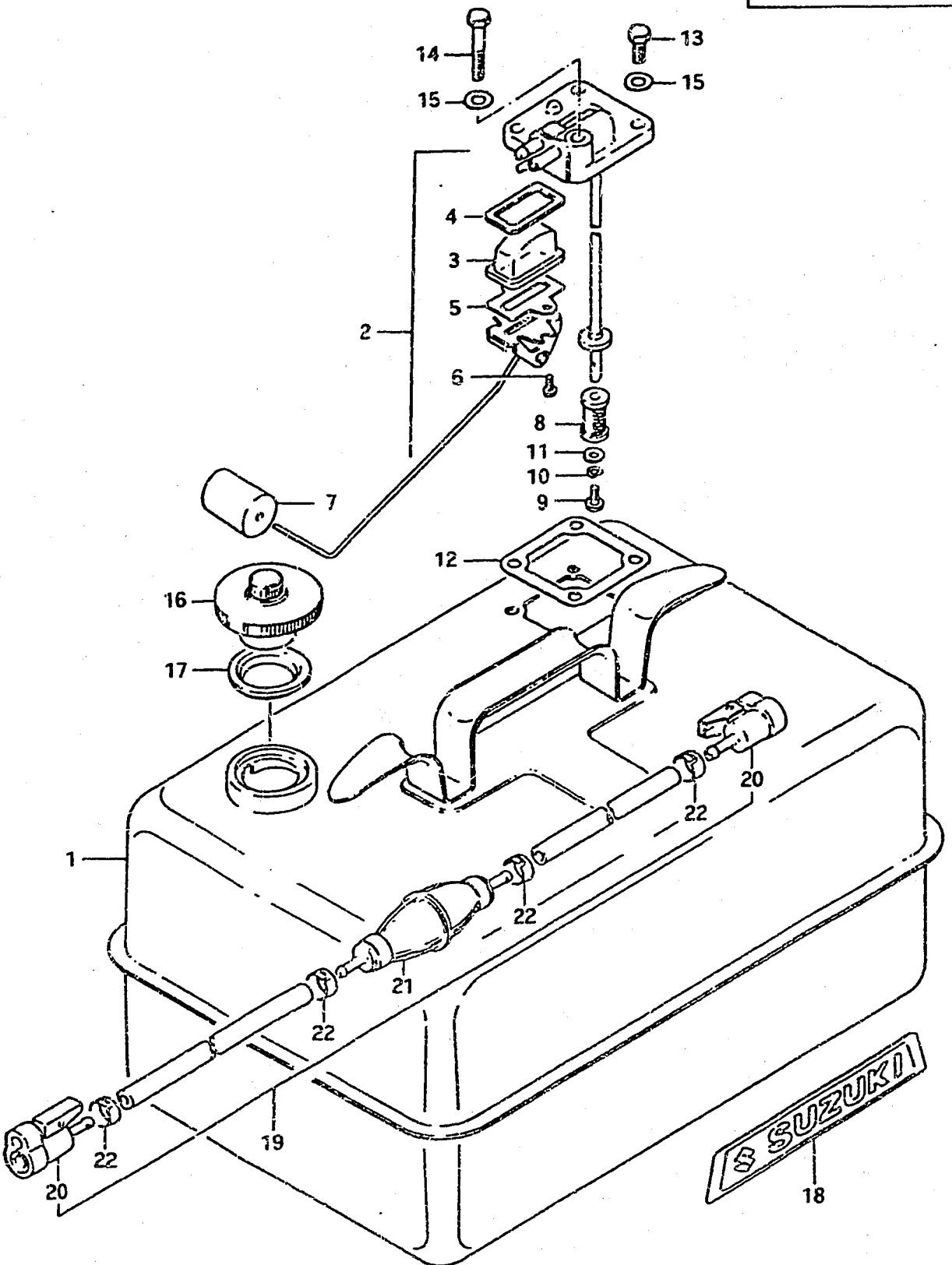

Ref. No.	Part No.	Description	Qty		Remarks
			C	D	
1-1	65800-93815	TANK ASSY, separate fuel (to 65800-93817)	1	-	23ℓ (6 U.S. GAL.) (5 IMP. GAL.)
1-2	65800-93817	TANK ASSY, separate fuel to (65800-93841)+(65700-99703)	-	1	23ℓ (6 U.S. GAL.) (5 IMP. GAL.)
2	65850-93002	•GAUGE ASSY, fuel	1	1	
3-1	65853-93000	••STRAINER (to 65853-93001)	1	1	
3-2	65853-93001	••STRAINER	1	1	
4	65854-93000	••GASKET, strainer	1	1	to 65854-93001
5	65862-93000	••GASKET, float arm holder	1	1	
6	02112-04108	••SCREW	2	2	
7	65864-93000	••FLOAT	1	1	
8	65830-93300	•FILTER (to 65830-93301)	1	1	DT9.9(C,D)E13
9	02112-05088	•SCREW	1	1	DT14(C,D)E13
10	08321-21058	•LOCK WASHER	1	1	DT16 D E13
11	08322-21058	•WASHER	1	1	DT16 C E37
12	65871-93001	•GASKET, fuel gauge	1	1	DT20(C,D)E13
13	01107-06168	•BOLT	3	3	DT25(C,D)E13
14	01107-06408	•BOLT	1	1	DT25 C E37
15	08322-21068	•WASHER	4	4	
16	65510-96000	•CAP, fuel tank	1	1	
17	44248-12000	•GASKET, fuel tank cap	1	1	
18	65312-99701	•EMBLEM, fuel tank (to 61441-98400)	2	2	
19	65700-99703	•HOSE ASSY, fuel (to 65700-99705)	1	1	
20	65750-99700	••SOCKET, fuel hose	2	2	
21	65770-99700	••PUMP, squeeze (to 65770-99701)	1	1	
22	09401-13402	••CLAMP	4	4	

FIG. 55 (K-2) : model C, D  
 FIG. 57 (K-4) : DE3  
 FIG. 58 (K-5) : model F

FIG.57

K-4

FIG.57 FUEL TANK 3

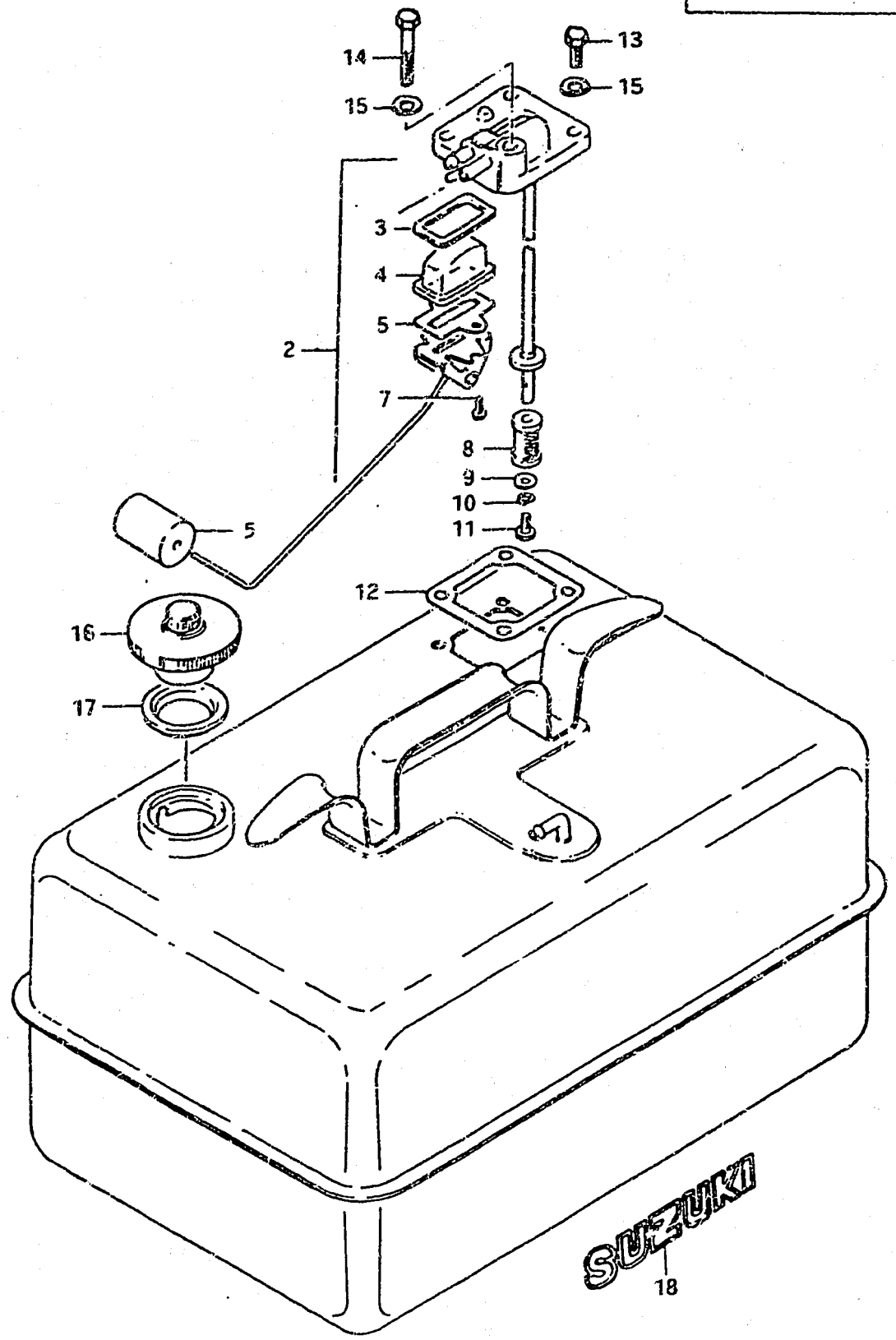

Ref. No.	Part No.	Description	Q'ty	Remarks
1	65800-93841	TANK SET, fuel separate 23ℓ (6 U.S. GAL.) (5 IMP. GAL.)	1	to 65800-95812
2	65850-93002	•GAUGE ASSY, fuel	1	
3	65854-93000	••GASKET, fuel gauge strainer1 (to 65854-93001)	1	
4	65853-93001	••STRAINER, fuel gauge	1	
5	65852-93000	••GASKET	1	
6	65864-93000	••FLOAT	1	
7	02112-04108	••SCREW	2	
8	65830-93301	••FILTER	1	DT9.9D E3 DT16D E3 DT20D E3 DT25D E3
9	08322-21058	••WASHER	1	
10	08321-21058	••LOCK WASHER	1	
11	02112-05088	••SCREW	1	
12	65871-93001	•GASKET, fuel gauge	1	
13	01107-06168	•BOLT	3	
14	01107-06408	•BOLT	1	
15	08322-21068	•WASHER	4	
16	65510-96000	•CAP, fuel tank	1	
17	44248-12000	•GASKET, fuel tank cap	1	
18	61441-98400	•EMBLEM, fuel tank (to 61441-98500)	2	

FIG.55 (K-2) : model C, D  
 FIG.56 (K-3) : (C, D)E13, CE37  
 FIG.58 (K-5) : model F

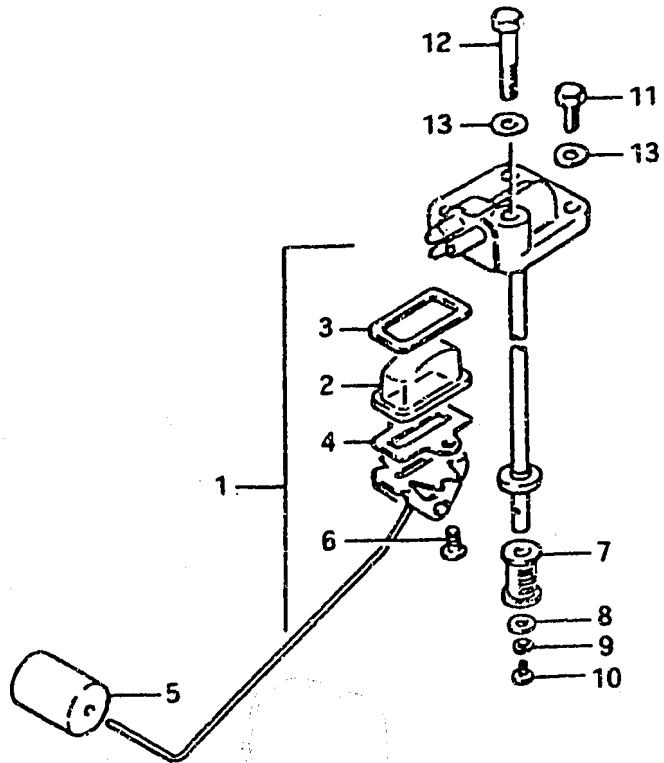

Ref. No.	Part No.	Description	Q'ty	Remarks
1-1	65850-95200	GAUGE ASSY, fuel	1	to 65850-95201
1-2	65850-95201	GAUGE ASSY, fuel (S mark)	1	
2	65853-93001	•STRAINER	1	to 65854-93001
3	65854-93000	•GASKET	1	
4	65852-93000	•GASKET	1	
5	65864-93000	•FLOAT	1	
6	02112-04108	•SCREW	2	DT9.9F(E3,E13,E38) DT9.9YF(E3) DT14F(E13,E38) DT16F(E3,E13,E38) DT20F DT25F,DT28F
7	65830-93301	•FILTER	1	
8	08322-21058	•WASHER	1	
9	08321-21058	•LOCK WASHER	1	
10	02112-05088	•SCREW	1	
11	01107-06168	BOLT	3	
12	01107-06403	BOLT	1	
13	08322-21068	WASHER	4	

FIG. 60 (K-7) : OUTLET ASSY, fuel

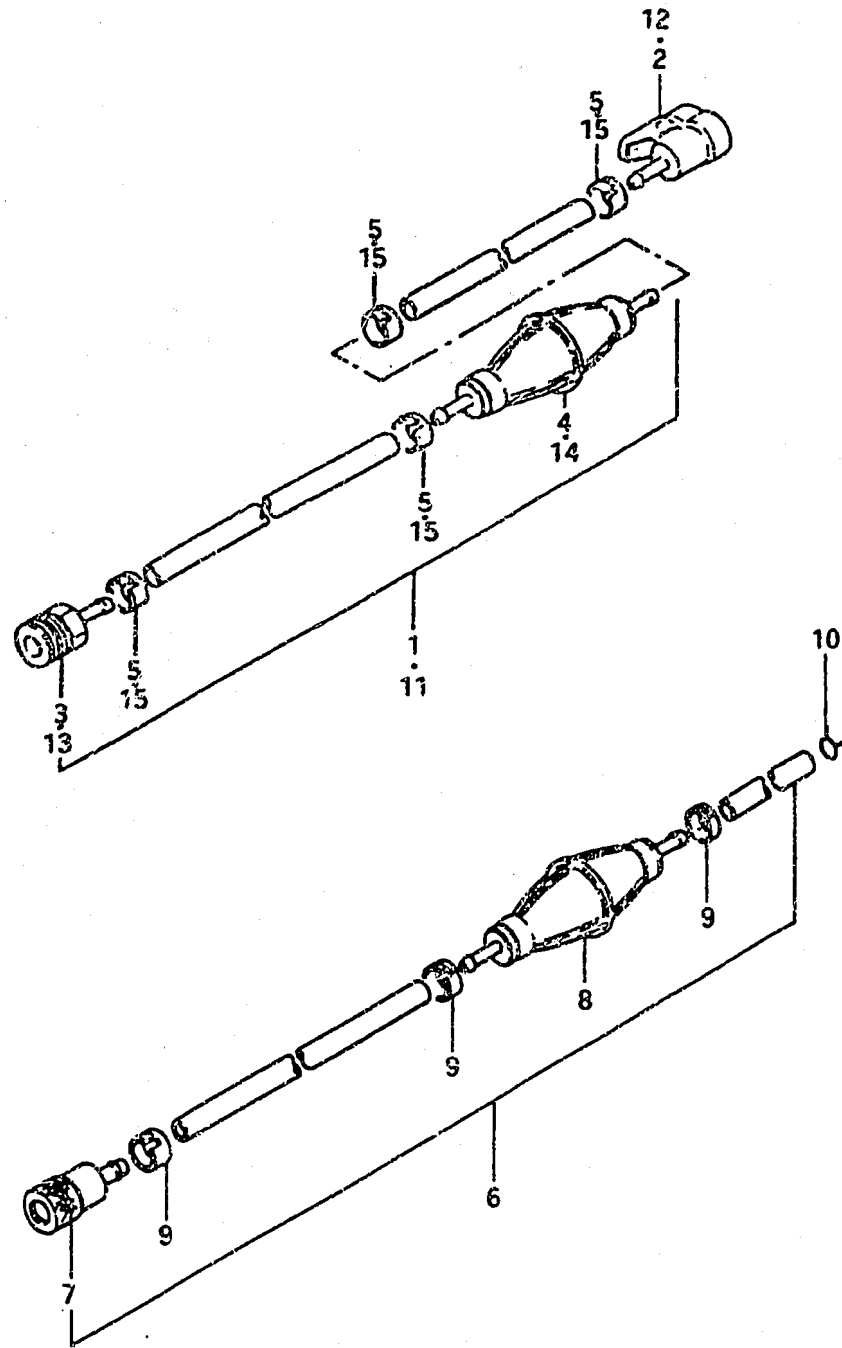

Ref. No.	Part No.	Description	Q'ty	Remarks
1	65700-98510	HOSE, fuel (to 65700-98511)	1	DT9.9D E3 DT9.9YF E3 DT9.9F(E3,E13,E38) DT14F(E13,E38)
2	65750-99700	•SOCKET, fuel hose	1	
3	65750-98500	•SOCKET, fuel hose (to 65750-98501)	1	
4	65770-99700	•PUMP, squeeze (to 65770-99701)	1	
5	09401-13402	•CLIP	4	
6	65700-98500	HOSE, fuel (to 65700-98501)	1	DT16D E3 DT16F(E3,E13,E38) DT20D E3 DT25D E3
7	65750-98500	•SOCKET, fuel hose (to 65750-98501)	1	
8	65770-99700	•PUMP, squeeze (to 65770-99701)	1	
9	09401-13402	•CLIP	3	
10	09401-11402	CLIP	1	
11	65700-95210	HOSE, fuel	1	DT9.9F DT14F DT16F DT20F DT25F DT28F
12	65750-99700	•SOCKET, fuel hose	1	
13	65750-98990	•SOCKET, fuel hose from 65750-98502	1	
14	65770-99701	•PUMP, squeeze to 65770-99702	1	
15	09401-13402	•CLIP	4	

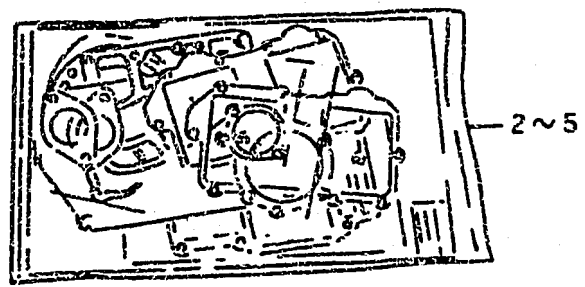
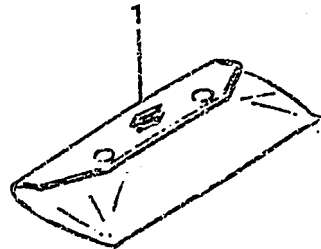
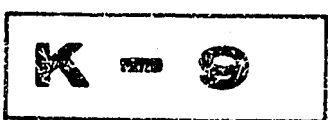

Ref. No.	Part No.	Description	Qty			Remarks
			C	D	F	
1-1	09800-00128	TOOL ASSY to 09800-00805	1	1	1	DT9.9, DT20(C,D,F) DT25(C,D) DT25F } for Hand DT28F } starter
1-2	09800-00179	TOOL ASSY to 09800-00805	-	-	1	DT20F } DT25F } for Electric DT28F } starter
2-1	11400-93830	GASKET SET, engine to 11400-93831	1	1	-	DT9.9
2-2	11400-93831	GASKET SET, engine to 11400-93832	-	1	1	
3-1	11400-93822	GASKET SET, engine to 11400-93823	1	1	-	DT14, DT16
3-2	11400-93823	GASKET SET, engine	-	1	1	OPT
4-1	11400-93850	GASKET SET, engine to 11400-93851	1	1	-	DT20
4-2	11400-93851	GASKET SET, engine to 11400-93852	-	1	1	
5-1	11400-93840	GASKET SET, engine to 11400-93860	1	1	-	DT25, DT28
5-2	11400-93860	GASKET SET, engine to 11400-93861	-	1	1	

FIG.63

K - 10

FIG.63 OPT : RECTIFIER SET (DT20, DT25, DT28)

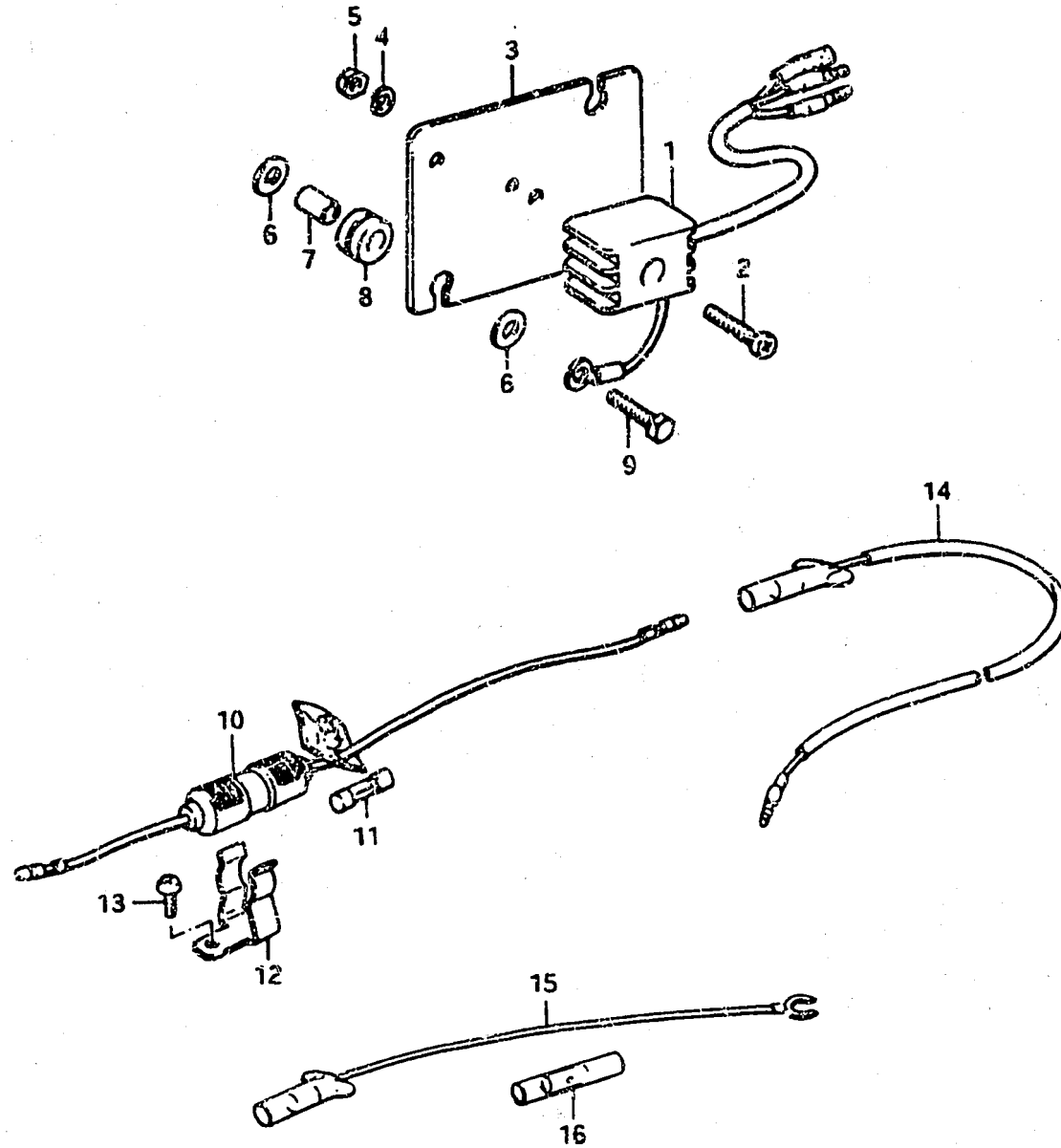

Ref. No.	Part No.	Description	Qty			Remarks
			C	D	F	
0-1	32800-93810	RECTIFIER SET (to 32800-98311)	1	1		
0-2	32800-93812	RECTIFIER SET	-	-	1	
1	32800-95720	RECTIFIER ASSY	1	1	1	
2	02112-05258	SCREW	1	1	1	
3	32890-93300	HOLDER, electric parts	1	1	1	
4	08321-21058	LOCK WASHER	1	1	1	
5	08310-11058	NUT	1	1	1	
6-1	09160-06019	WASHER, electric parts holder (6.5x16x1.2)	4	4	-	
6-2	09160-06052	WASHER, electric parts holder (6.5x16x1.2)	-	-	2	
7	09180-06035	SPACER, electric parts holder	2	2	2	DT20,DT25,DT28
8	09320-08015	CUSHION, electric parts holder	2	2	2	for Hand Starter
9	01107-06258	BOLT	2	2	2	
10-1	36740-95250	CASE ASSY, fuse (to 36740-95251)	1	1	-	
10-2	36740-95252	CASE ASSY, fuse	-	1	1	from 36740-95251
11	09481-20001	FUSE (20A)	1	1	1	
12	36791-95200	HOLDER, fuse	-	1	1	
13-1	09125-06020	SCREW (L:16)	1	1	-	
13-2	09125-06025	SCREW (L:20)	-	-	1	
14	36897-93300	LEAD WIRE, fuse case	1	1	1	
15	36898-93300	LEAD WIRE, consent earth	1	1	1	
16	37132-93700	WIRE CONNECTOR	1	1	1	



FIG. 65

K - 12

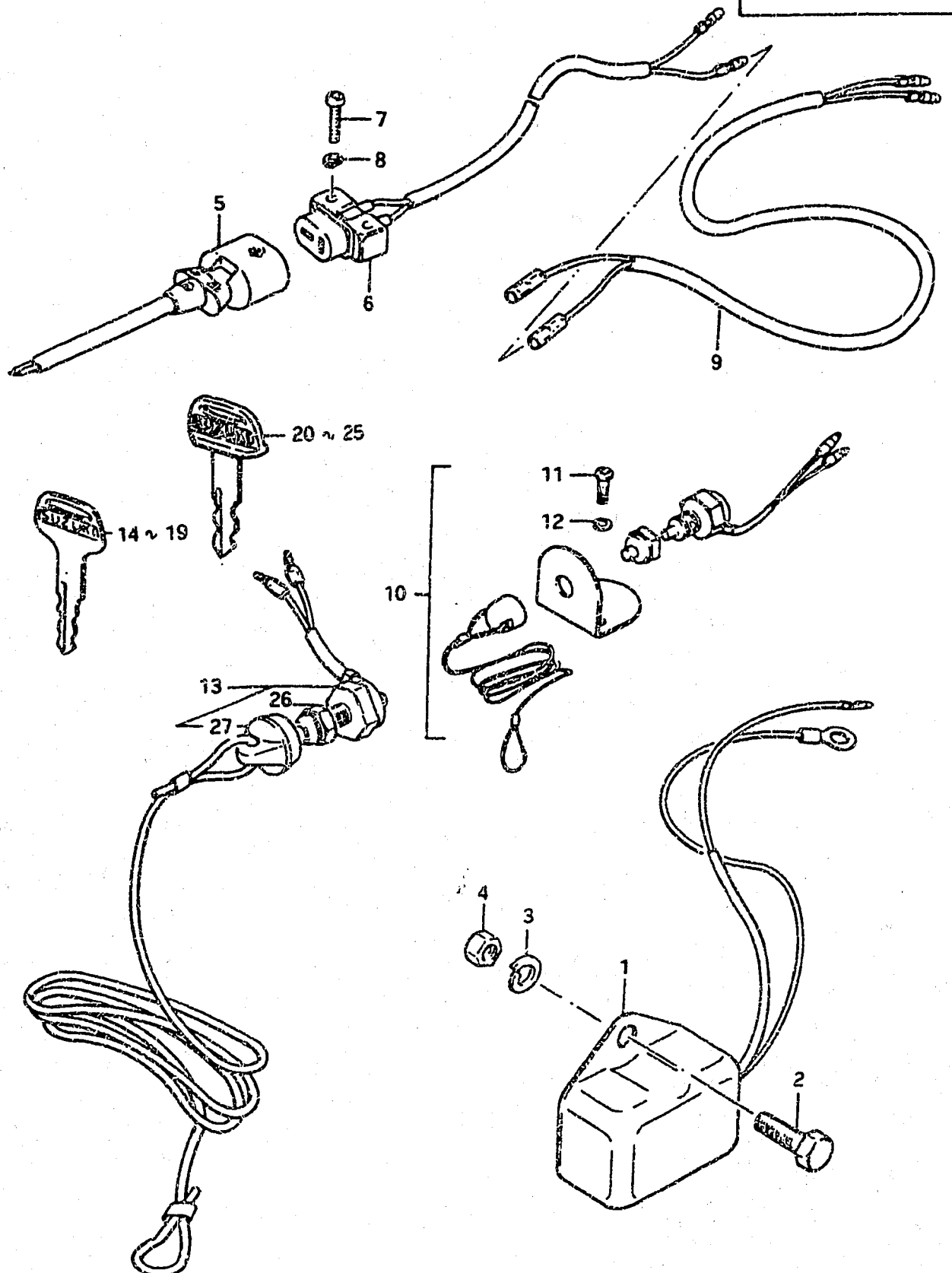
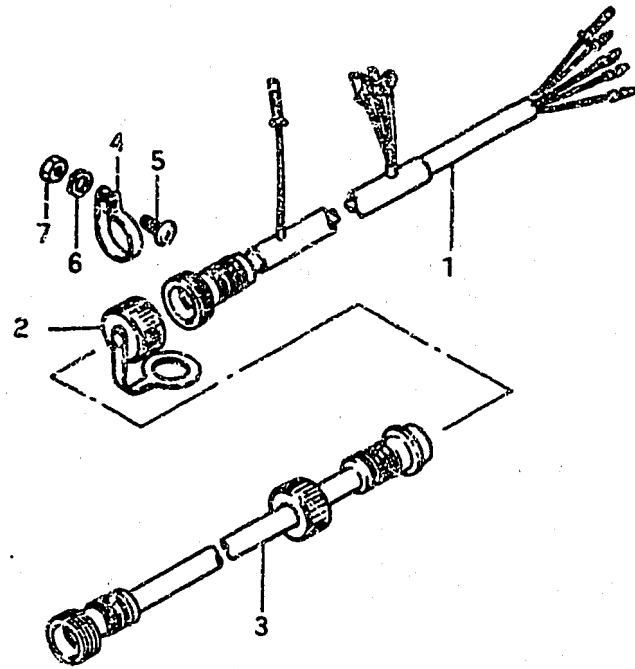

FIG. 65 OPT : ELECTRICAL (DT20, DT25, DT28)

Ref. No.	Part No.	Description	Q'ty			Remarks
			C	D	F	
1	32500-95721	REGULATOR ASSY, voltage	1	1	1	from 32500-95720
2	01107-06208	BOLT	2	2	2	
3	08321-21068	LOCK WASHER	2	2	2	
4	08310-11068	NUT	2	2	2	
5	39502-99711	PLUG ASSY, lamp cord (L:2000)	1	1	1	
6	39601-95711	CONSENT ASSY, lamp	-	1	1	
7	02112-04203	SCREW	-	2	2	for Hand Starter
8	08322-21048	WASHER	-	2	2	
9	36896-93300	LEAD WIRE, consent	-	1	1	
10-1	37800-93810	SWITCH SET, emergency	1	1	-	to 37800-93811
10-2	37800-93812	SWITCH SET, emergency	-	1	1	from 37800-93811
11	09125-04011	SCREW (4x16)	2	2	2	
12	08321-21048	LOCK WASHER	2	2	2	DT20,DT25,DT28
13-1	37820-95251	SWITCH ASSY, emergency (Incl. Ref. No. 26, 27) (T:3)	1	-	-	for Electric Starter
13-2	37820-95351	SWITCH ASSY, emergency (T:2)	-	1	1	from 37820-95350
14	37141-95200	KEY, spare (8111)	1	1	-	
15	37141-95210	KEY, spare (8112)	1	1	-	
16	37141-95220	KEY, spare (8113)	1	1	-	
17	37141-95230	KEY, spare (8211)	1	1	-	
18	37141-95240	KEY, spare (8212)	1	1	-	
19	37141-95250	KEY, spare (8213)	1	1	-	
20	37141-93300	KEY, spare (8511)	-	-	1	
21	37141-93310	KEY, spare (8512)	-	-	1	
22	37141-93320	KEY, spare (8513)	-	-	1	
23	37141-93330	KEY, spare (8611)	-	-	1	
24	37141-93340	KEY, spare (8612)	-	-	1	
25	37141-93350	KEY, spare (8613)	-	-	1	
26	37822-95251	NUT, emergency	1	-	-	
27	37823-95251	CAP, emergency	1	-	-	



Ref. No.	Part No.	Description	Q'ty 20~28	Remarks
1	36630-93300	WIRING HARNESS, remote control (L:650)	1	DT20,DT25,DT28 for TSK remote control box (67200-95300)
2	36631-93750	CAP	1	
3	36620-95250	WIRING HARNESS, extension (L:5000)	1	
4	36659-93300	CLAMP, connector	1	
5	09125-05025	SCREW (5x12)	1	
6	09160-05010	WASHER (5.5x10x0.8)	1	
7	09140-05001	NUT	1	

FIG.67

K - 14

FIG.67 OPT : ELECTRIC STARTING KIT (DT20C, DT25C)

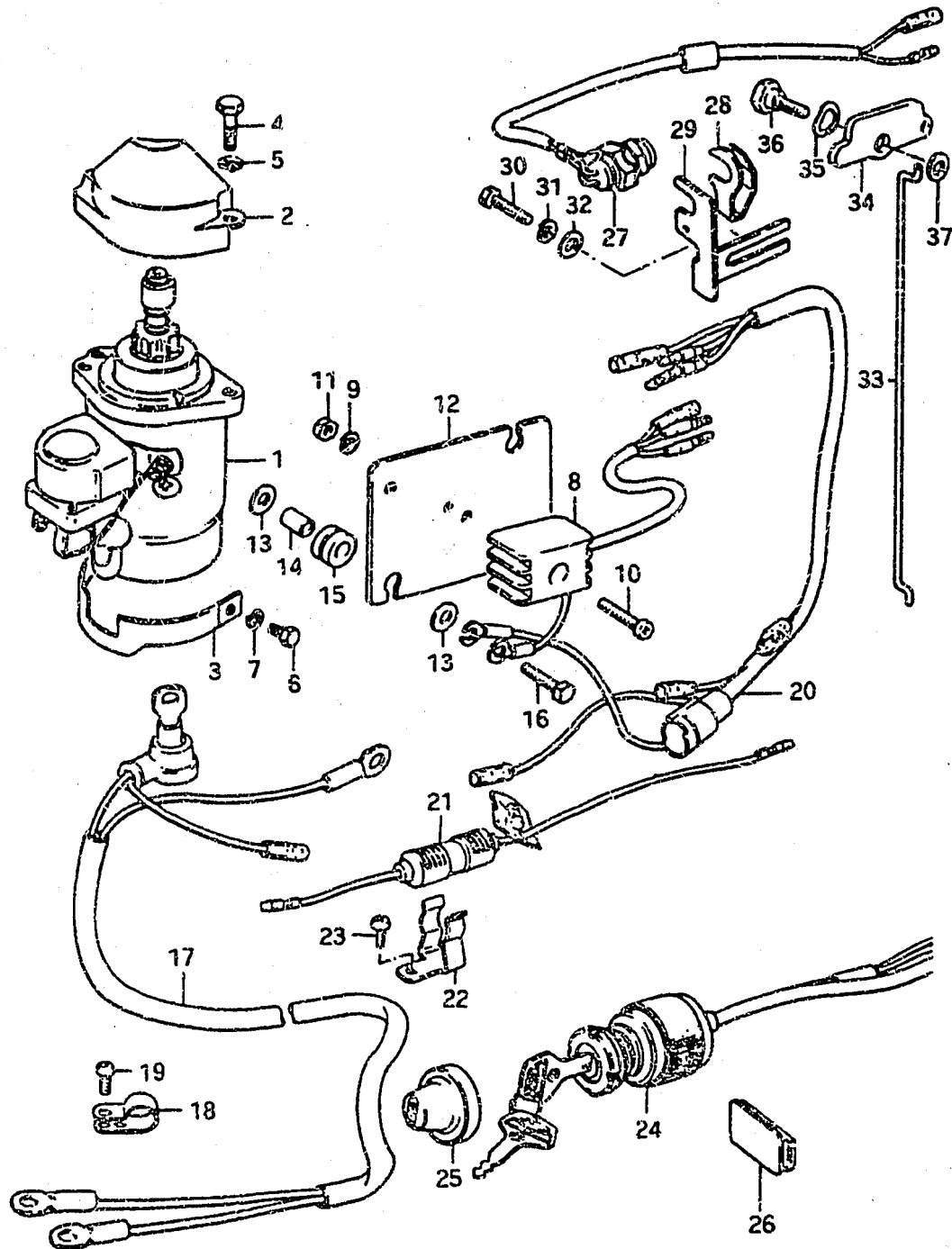

Ref. No.	Part No.	Description	Q'ty		Remarks
			20,25		
0-1	33300-93811	ELECTRIC STARTING KIT	1		to 33300-93812
0-2	33300-93812	ELECTRIC STARTING KIT	1		to 33300-93813
1	31100-95240	·MOTOR ASSY, starting	1		to 31100-95241
2	31914-93300	·COVER, starting motor	1		
3	31912-93300	·BAND, starting motor	1		
4	01107-08408	·BOLT	2		
5	08321-21088	·LOCK WASHER	2		
6	01107-06168	·BOLT	2		
7	08321-21068	·LOCK WASHER	2		
8	32800-95720	·RECTIFIER ASSY	1		
9	08321-21058	·LOCK WASHER	1		
10	02112-05258	·SCREW	1		
11	08310-11058	·NUT	1		
12	32890-93300	·HOLDER, electric parts	1		DT20C,DT25C for Hand Starter
13	09160-06019	·WASHER (6.5x16x1.2)	4		
14	09180-06035	·SPACER (6.1x8x12)	2		
15	09320-08015	·CUSHION	2		
16	01107-06258	·BOLT	2		
17	33810-93300	·CABLE ASSY, starting motor (to 33810-93301)	1		L:1870(-) L:1680(+)
18	36659-93300	·CLAMP, starting motor	1		
19	02142-04127	·SCREW	1		
20	36610-93350	·WIRING HARNESS (1)	1		
21	36740-95250	·CASE ASSY, fuse (to 36740-95251)	1		
22	36791-95200	·HOLDER, fuse case	1		
23	09125-06020	·SCREW	1		

FIG. 67

K - 15

FIG. 67 OPT : ELECTRIC STARTING KIT (DT20C, DT25C)

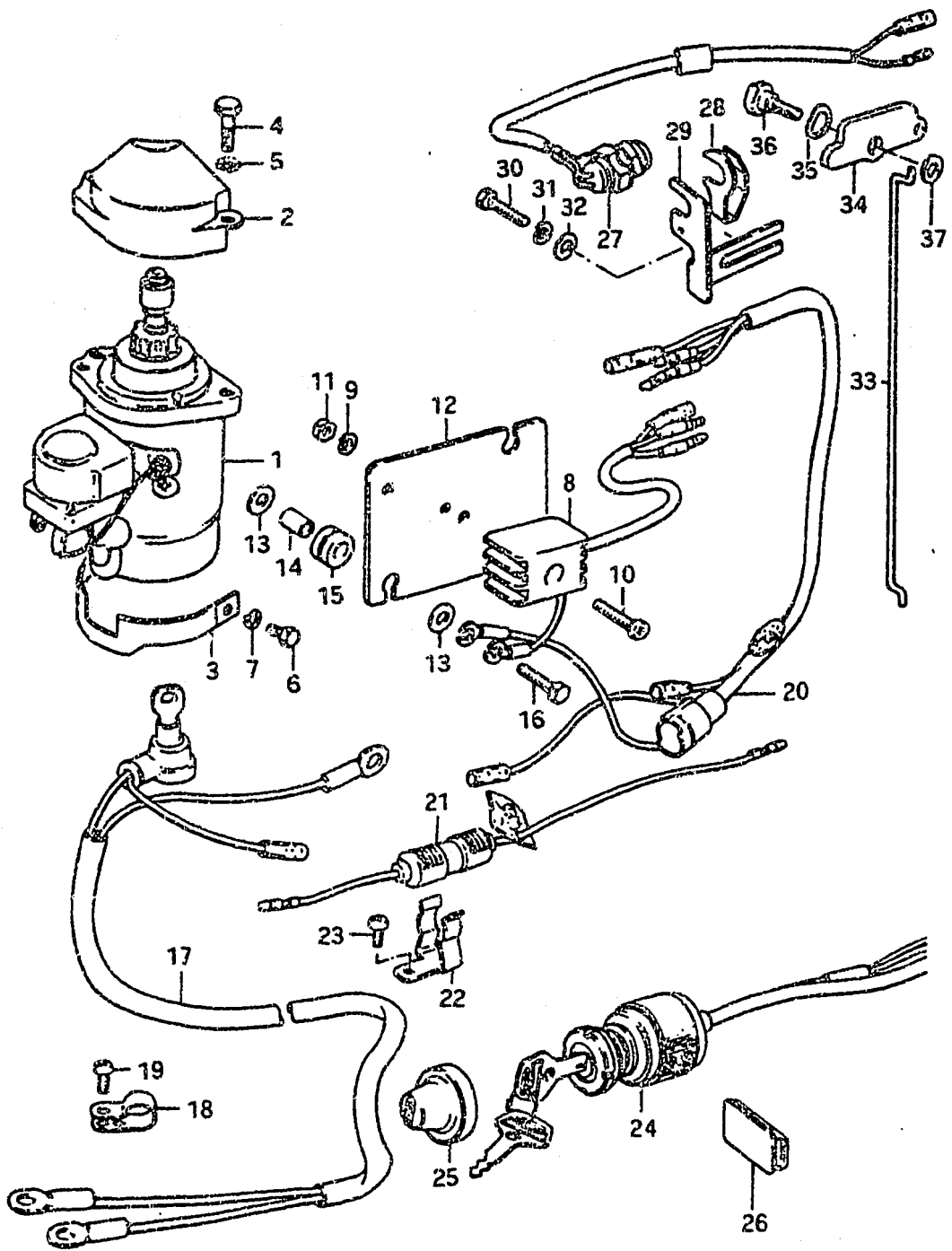

Ref. No.	Part No.	Description	Q'ty		Remarks
			20,25		
24	37110-93350	•SWITCH ASSY, ignition	1		
25	37921-97001	•COVER, ignition switch	1		
26	39669-93500	•CAP, consent	1		from 39669-93300
27	37721-95250	•SWITCH ASSY, neutral	1		
28	37725-95201	•ACTUATOR, neutral switch	1		
29	37726-93301	•BRACKET, neutral switch	1		to 37726-93302
30	09100-06020	•BOLT, neutral switch bracket	1		6x20
31	09162-06001	•LOCK WASHER, neutral switch bracket	1		DT20C,DT25C
32	09160-06015	•WASHER, neutral switch bracket	1		for Hand Starter
33	21312-93300	•ROD, interlock	1		
34	21313-93300	•PLATE, interlock	1		
35	09164-09002	•WAVE WASHER, interlock plate	1		
36	09111-06022	•BOLT, interlock plate	1		to 09111-06025
37	09160-06017	•WASHER, interlock plate	1		

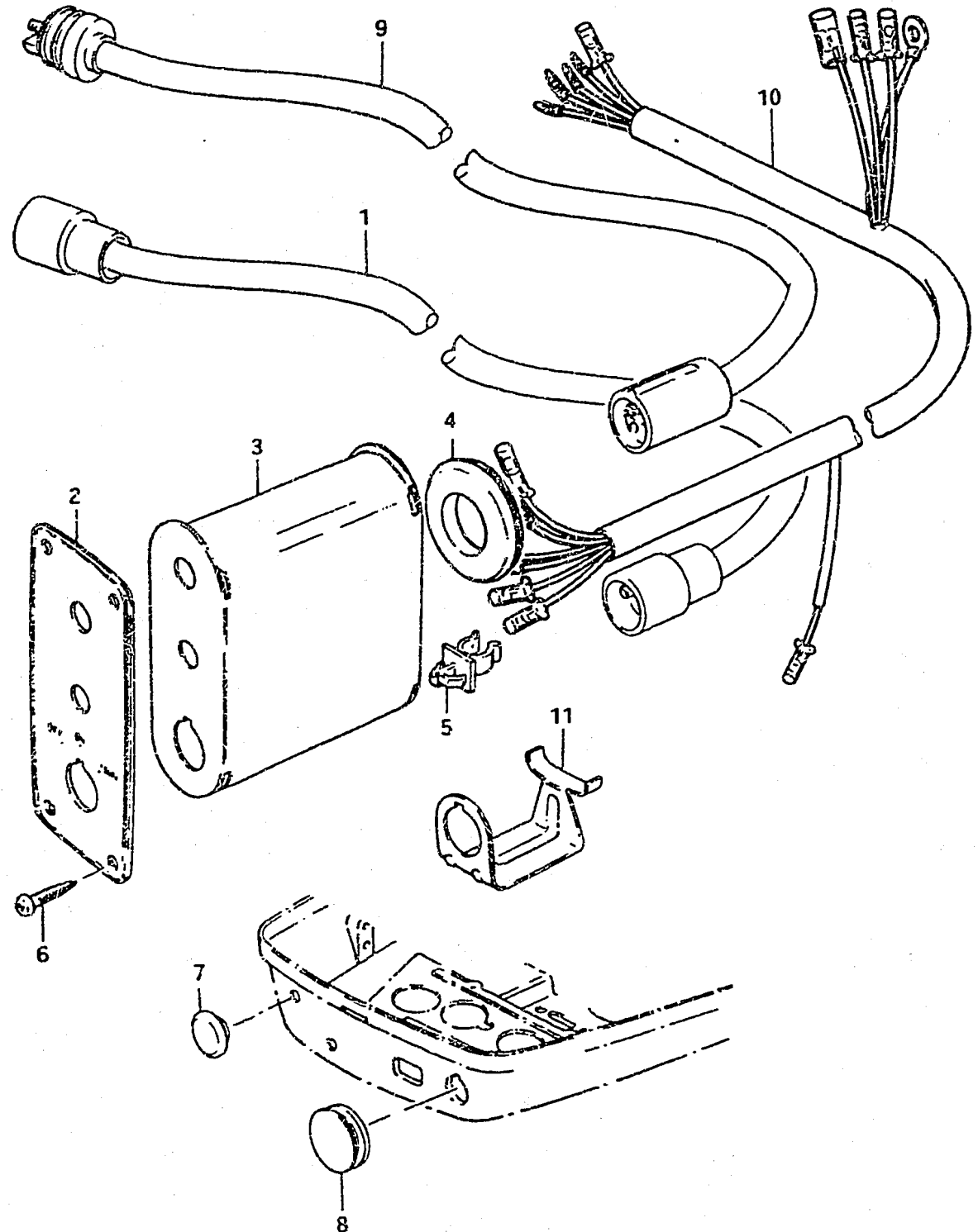

Ref. No.	Part No.	Description	C	D	F	Remarks
0-1	33300-93820	REMOTE STARTING KIT	1	-	-	to 33300-93821
0-2	33300-93840	REMOTE STARTING KIT	-	1	-	
1	36620-93350	•WIRING HARNESS ASSY (L:5000)	1	1	-	
2-1	37139-95250	•PLATE, ignition switch	1	1	-	to 37139-95251
2-2	37139-95251	•PLATE, ignition switch	-	1	1	
3	37143-95250	•HOUSING, switch	1	-	-	
4	36657-95250	•GROMMET, switch housing	1	-	-	DT20,DT25,DT28
5	09403-09309	•CLAMP, switch housing	1	-	-	
6	03112-05209	•SCREW, panel assy	4	4	4	
7-1	37101-93300	•CAP, panel assy	1	1	-	to 37101-93301
7-2	37101-93301	•CAP, panel assy	-	1	2	
8	09250-20004	•CAP, ignition switch	1	1	*1	*model F→for Electric starter
9	36620-93300	WIRING HARNESS (2) (L:5000)	-	1	-	
10	36620-93700	WIRING HARNESS, extension	-	-	1	L:5000 to 36620-93702
11	37150-95250	CLAMP, ignition switch	-	1	1	from 37150-95200

FIG.70

L - 5

FIG.70 OPT : REMOTE CONTROL (DT20, DT25)

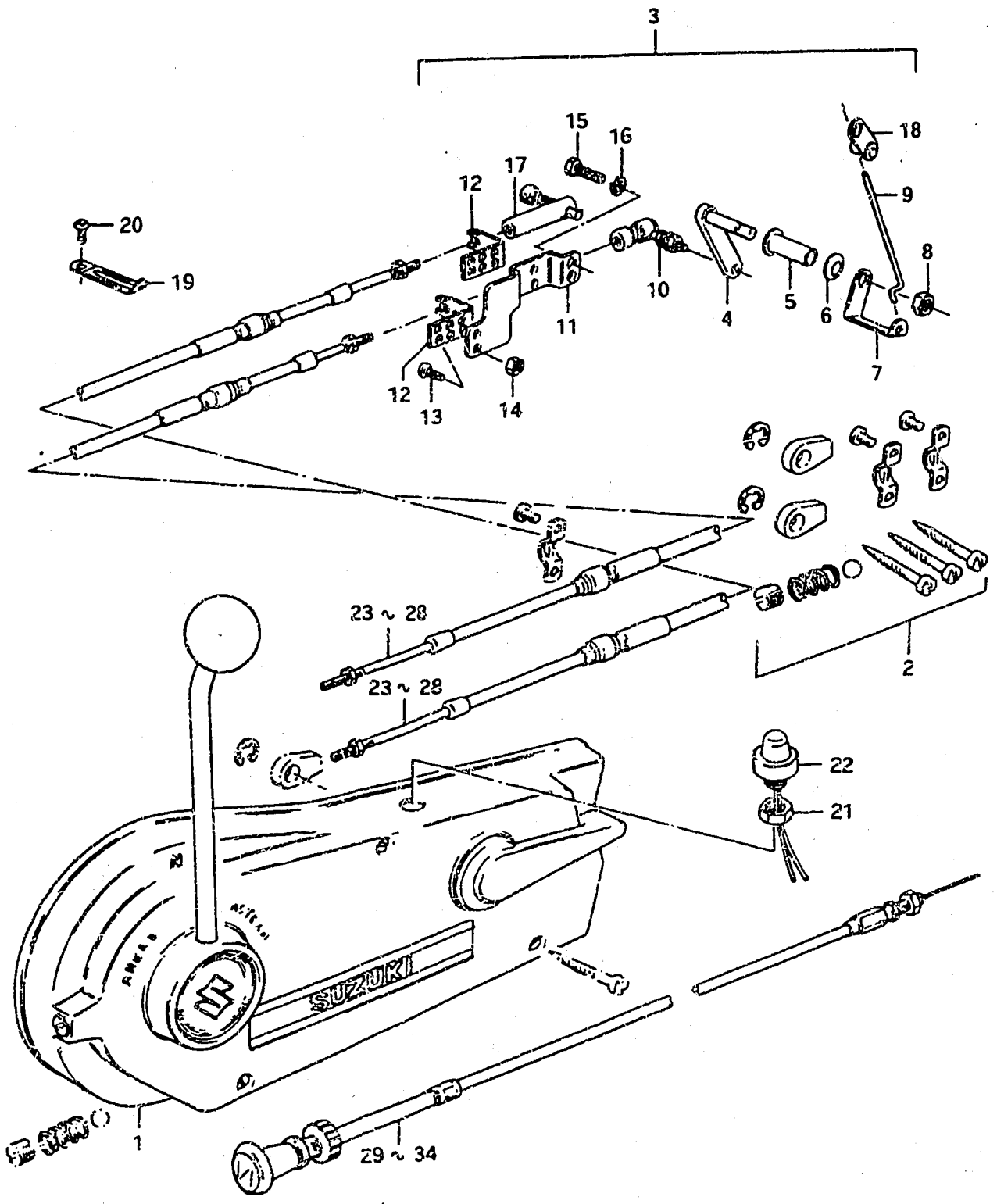

Ref. No.	Part No.	Description	Q'ty		Remarks
			C	D	
1	67200-95200	BOX ASSY, remote control	1	1	to 67200-95201
2	67300-95810	•HOLDER SET, control cable	1	1	
3	67130-93000	REMOTE CONTROL PARTS ASSY	1	1	
4	67410-93701	•LEVER, throttle	1	1	
5	09306-08009	•BUSHING	1	1	
6	09164-09002	•WAVE WASHER	1	1	
7	67414-93701	•LEVER, throttle (2)	1	1	
8	09140-08003	•NUT	1	1	
9	67413-93701	•ROD, throttle	1	1	
10	67431-93701	•GUIDE, throttle cable	1	1	
11	67341-93701	•HOLDER, attachment	1	1	
12	67345-93701	•STOPPER, cable	2	2	
13	09125-05028	•SCREW (5x12)	4	4	
14	09140-05001	•NUT	4	4	
15	09100-06019	•BOLT (6x16)	2	2	
16	09162-06001	•LOCK WASHER	2	2	
17	67440-93701	•GUIDE, clutch cable	1	1	DT20 (C,D) DT25 (C,D)
18	67470-93701	•LEVER, throttle (Carbu side)	1	1	
19	09404-06401	•CLAMP, stop switch wire (L:50)	1	1	
20	09125-04108	•SCREW (4x6)	2	2	
21	09140-14014	•NUT	1	1	
22	37870-93704	•SWITCH ASSY, engine stop	1	1	
23	67320-95750	CABLE ASSY, clutch (L:2500)	2	2	
24	67320-95740	CABLE ASSY, clutch (L:3000)	2	2	
25	67320-95730	CABLE ASSY, clutch (L:3500)	2	2	
26	67320-95720	CABLE ASSY, clutch (L:4000)	2	2	
27	67320-95710	CABLE ASSY, clutch (L:4500)	2	2	
28	67320-95200	CABLE ASSY, clutch (L:5000)	2	2	
29	63720-95750	CABLE ASSY, choke (L:4000)	1	1	
30	63720-95740	CABLE ASSY, choke (L:4500)	1	1	
31	63720-95730	CABLE ASSY, choke (L:5000)	1	1	
32	63720-95720	CABLE ASSY, choke (L:5500)	1	1	
33	63720-95710	CABLE ASSY, choke (L:6000)	1	1	
34	63720-95200	CABLE ASSY, choke (L:6500)	1	1	

FIG.69 (L-3, 4) : DT9.9, DT14, DT16  
 FIG.71 (L-6) : DT20F, DT25F, DT28F

FIG.71

L - 6

19

FIG.71 OPT : REMOTE CONTROL (DT20F, DT25F, DT28F)

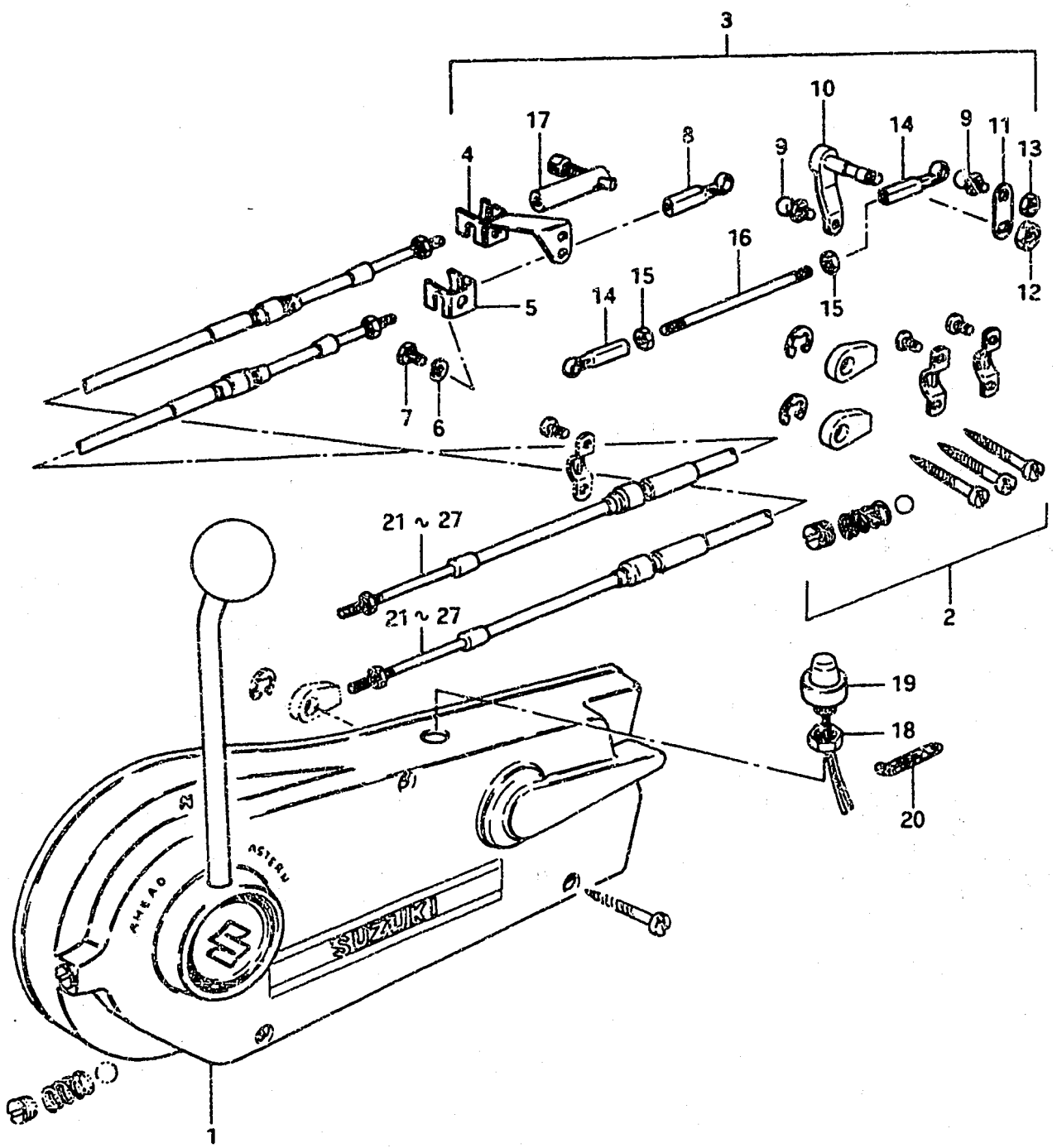

Ref. No.	Part No.	Description	Q'ty	Remarks
1	67200-95200	BOX ASSY, remote control	1	to 67200-95201
2	67300-95810	·HOLDER SET	1	
3	67130-93400-01J	REMOTE CONTROL PARTS ASSY	1	to 67130-93401-01J
4	67340-93400	·HOLDER	1	
5	57341-93400	·HOLDER	1	
6	09162-06001	·LOCK WASHER	3	
7	09100-06019	·BOLT (6x16)	3	
8	67466-95200	·CONNECTOR, cable	1	
9	09119-06047	·BALL, pivot	2	from 09119-06039
10	67410-93400-01J	·LEVER, throttle	1	to 67410-93401-01J
11	67417-93400	·ARM, throttle	1	
12	09140-08003	·NUT	1	
13	09140-06004	·NUT	1	DT20F DT25F DT28F
14	67463-95200	·CONNECTOR, control	2	
15	09140-05001	·NUT	2	
16	67413-93400	·ROD, throttle (L:137)	1	
17	67440-93701	·GUIDE, clutch cable	1	
18	09140-14014	·NUT	1	
19	37870-93704	·SWITCH ASSY, engine stop	1	
20	09404-06401	·CLAMP, stop switch wire	1	
21	67320-95750	CABLE ASSY, clutch (L:2500)	2	
22	67320-95740	CABLE ASSY, clutch (L:3000)	2	
23	57320-95730	CABLE ASSY, clutch (L:3500)	2	
24	67320-95720	CABLE ASSY, clutch (L:4000)	2	
25	67320-95710	CABLE ASSY, clutch (L:4500)	2	
26	67320-95200	CABLE ASSY, clutch (L:5000)	2	
27	67320-95760	CABLE ASSY, clutch (L:6000)	2	

FIG.69 (L-3, 4) : DT9.9, DT14, DT16  
 FIG.70 (L-5) : DT20 (C, D), DT25 (C, D)

FIG.72

L - 7

FIG.72 OPTIONAL

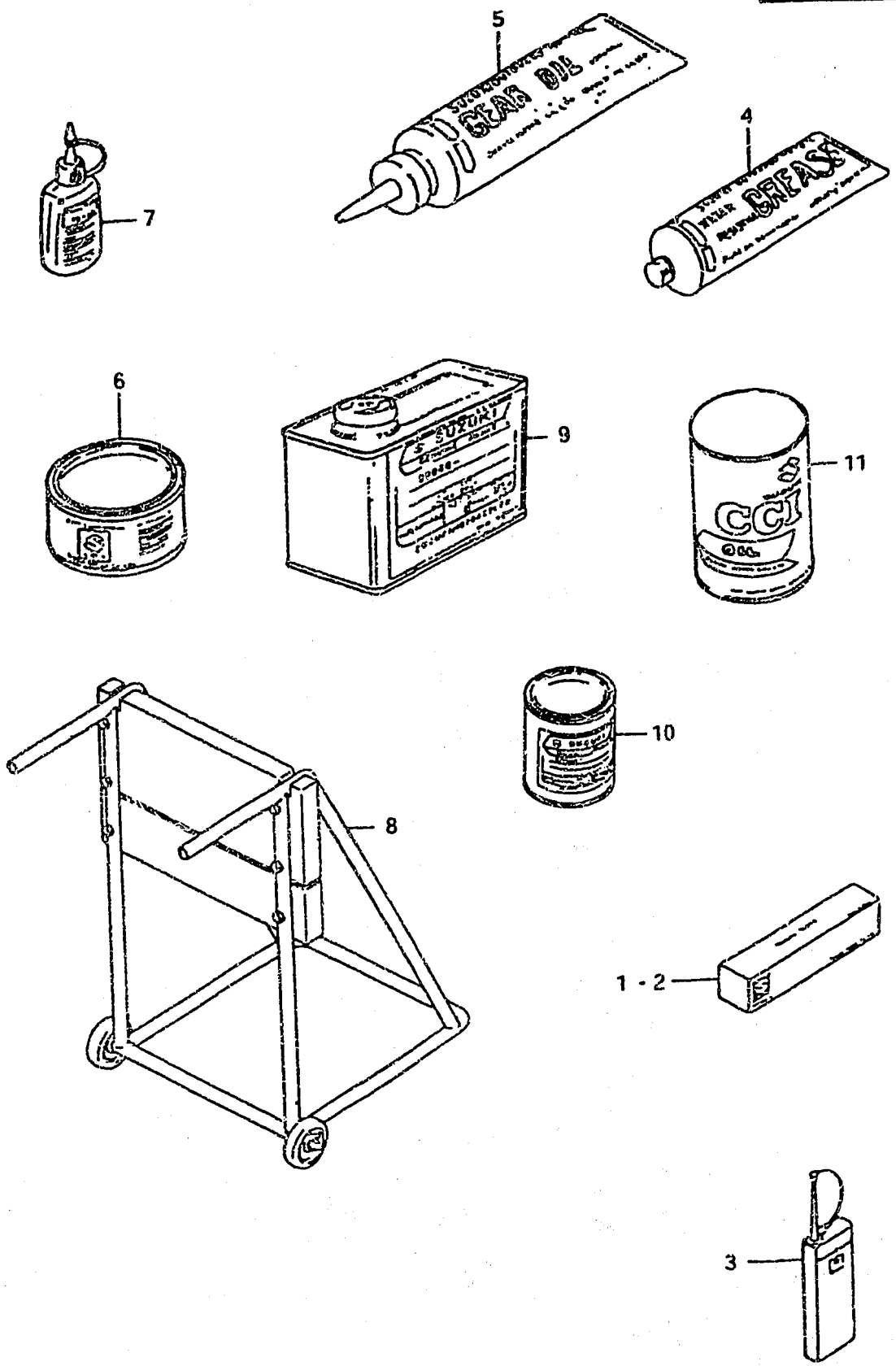

Ref. No.	Part No.	Description	Qty 9.9-28	Remarks
1	99000-31030	GASKET, liquid	1	for crankcase,100g
2	99000-31050	GASKET, liquid	1	for gear case,100g
3	99000-32040	CEMENT, thread lock	1	200g
4-1	99000-25160	GREASE, water resistant	1	250g
4-2	99000-25170	GREASE, water resistant	1	50g
5	99000-22540	GEAR OIL, outboard motor	1	400cc
6	99000-25010	SUZUKI SUPER GREASE A	1	450g,for crank oil seal
7	99000-32030	SUZUKI LOCK SUPER	1	50g (1303B)
8-1	09914-39941	HANGER, engine	1	DT9.9,DT14 DT16,DT20 DT25,DT28
8-2	09914-39950	HANGER, engine	1	
9-1	99000-10105-01T	PAINT (Francois White No.2)	1	
9-2	99000-10205-01J	PAINT (Andes Blue Metallic)	1	90g
10-1	99000-10109-01T	PAINT (Francois White No.2)	1	
10-2	99000-10209-01J	PAINT (Andes Blue Metallic)	1	
11-1	99000-21460	CCI OIL (12x24,MITSUBISHI)	1	
11-2	99000-21145	CCI OIL (12x24,SHELL)	1	
11-3	99000-21021	CCI OIL (42x6)	1	
11-4	99000-21150	CCI OIL (2002)	1	
11-5	99000-21250	CCI SUPER OIL (12x24)	1	
11-6	99000-21260	CCI SUPER OIL (42x6)	1	